

# INSTALLATION INSTRUCTIONS

## R-410A Two-Stage Split System Air Conditioner

Product Family: H4A6, C4A6, T4A6  
H4A8, C4A8, T4A8

These instructions must be read and understood completely before attempting installation.

### Safety Labeling and Signal Words

#### DANGER, WARNING, CAUTION, and NOTE

The signal words **DANGER**, **WARNING**, **CAUTION**, and **NOTE** are used to identify levels of hazard seriousness. The signal word **DANGER** is only used on product labels to signify an immediate hazard. The signal words **WARNING**, **CAUTION**, and **NOTE** will be used on product labels and throughout this manual and other manuals that may apply to the product.

**DANGER** – Immediate hazards which **will** result in severe personal injury or death.

**WARNING** – Hazards or unsafe practices which **could** result in severe personal injury or death.

**CAUTION** – Hazards or unsafe practices which **may** result in minor personal injury or product or property damage.

**NOTE** – Used to highlight suggestions which **will** result in enhanced installation, reliability, or operation.

#### Signal Words in Manuals

The signal word **WARNING** is used throughout this manual in the following manner:



The signal word **CAUTION** is used throughout this manual in the following manner:



#### Signal Words on Product Labeling

Signal words are used in combination with colors and/or pictures on product labels.

### TABLE OF CONTENTS

Inspect New Unit .....	2
Safety Considerations .....	2
Location .....	2
Clearances .....	2 – 3
Unit Support .....	4
Refrigeration System .....	4 – 8
Electrical Wiring .....	8
Airflow Selection .....	9
Start-up Procedure .....	9
Refrigerant Charge .....	9 – 10
Sequence of Operation .....	10
Compressor Operation .....	11
Troubleshooting .....	11 – 12
Maintenance .....	12
Diagnostics .....	13 – 14
R-410A Quick Reference Guide .....	15

## WARNING

**PERSONAL INJURY, AND/OR PROPERTY DAMAGE HAZARD**

Failure to carefully read and follow this warning could result in equipment malfunction, property damage, personal injury and/or death.

Installation or repairs made by unqualified persons could result in equipment malfunction, property damage, personal injury and/or death.

The information contained in this manual is intended for use by a qualified service technician familiar with safety procedures and equipped with the proper tools and test instruments.

Installation must conform with local building codes and with the National Electrical Code NFPA70 current edition or Canadian Electrical Code Part 1 CSA C.22.1.

## INSPECT NEW UNIT

After uncrating unit, inspect thoroughly for hidden damage. If damage is found, notify the transportation

company immediately and file a concealed damage claim.

## SAFETY CONSIDERATIONS

Consult a qualified installer, service agency, or the dealer/distributor for information and assistance. The qualified installer must use factory authorized kits and accessories when modifying this product. Refer to the individual instructions packaged with the kit or accessory when installing.

The weight of the product requires careful and proper handling procedures when lifting or moving to avoid personal injury. Use care to avoid contact with sharp or pointed edges.

Follow all safety codes. Wear safety glasses, protective clothing, and work gloves. Use a heat sinking material – such as a wet rag – during brazing operations. Keep a fire extinguisher available. Consult local codes and the National Electric Code (NEC) for special requirements.

Improper installation, adjustment, alteration, service or maintenance can void the warranty.



### WARNING

#### ELECTRICAL SHOCK HAZARD

**Failure to follow this warning could result in personal injury or death.**

**Before installing, modifying or servicing system, turn OFF the main (remote) electrical disconnect device. There may be more than one disconnect device. Lock out and tag switch with a suitable warning label.**



### CAUTION

#### PROPERTY DAMAGE HAZARD

**Failure to follow this caution may result in property damage**

**R-410A systems operate at higher pressures than R-22 systems. When working with R-410A systems, use only service equipment and replacement components specifically rated or approved for R-410A service.**

## LOCATION

Check local codes for regulations concerning zoning, noise, platforms, and other issues.

Locate unit away from fresh air intakes, vents, or bedroom windows. Noise may carry into the openings and disturb people inside.

Locate unit in a well drained area, or support unit high enough so that water runoff will not enter the unit.

Locate unit away from areas where heat, lint, or exhaust fumes will be discharged onto unit (as from dryer vents).

Locate unit away from recessed or confined areas where recirculation of discharge air may occur (refer to CLEARANCES section of this document).

Roof-top installation is acceptable providing the roof will support the unit and provisions are made for water drainage and noise/vibration dampening.

**NOTE:** Roof mounted units exposed to wind may require wind baffles. Consult the manufacturer for additional information.

## CLEARANCES

Nominal minimum clearances are 48 inches (1.2m) above unit for discharge air and 18 inches (457mm) on each side of the coil for intake air. Clearance on any **one** side of the coil (normally between unit and structure) may be reduced to 6 inches (152mm). Nominal minimum clearances are based on a solid parallel object such as a wall or roof overhang.

The clearance may be reduced for a single object with small surface area, such as the end of a wall, outside corner of a wall, fence section, post, etc. As a general rule, the minimum clearance from the unit should equal the width of the object. For example, a 6 inch (152mm) fence post should be a minimum of 6 inches (152mm) from the unit.

Do not install unit under roof overhangs unless gutters are present. A minimum vertical clearance of 48 inches (1.2m) is required to the overhang.

Inside corner locations on single story structures require evaluation. Large overhanging soffits may cause air recirculation in a corner area even though recommended minimum clearances are maintained. As a guide, locate the unit far enough out so that half of the discharge grille is out from under the soffit.

When placing two or more units side-by-side, provide a minimum of 18 inches (457mm) between units.

Provide minimum service clearance of 24 inches (610mm) from control box corner and side service panel.

Refer to Figure 1.

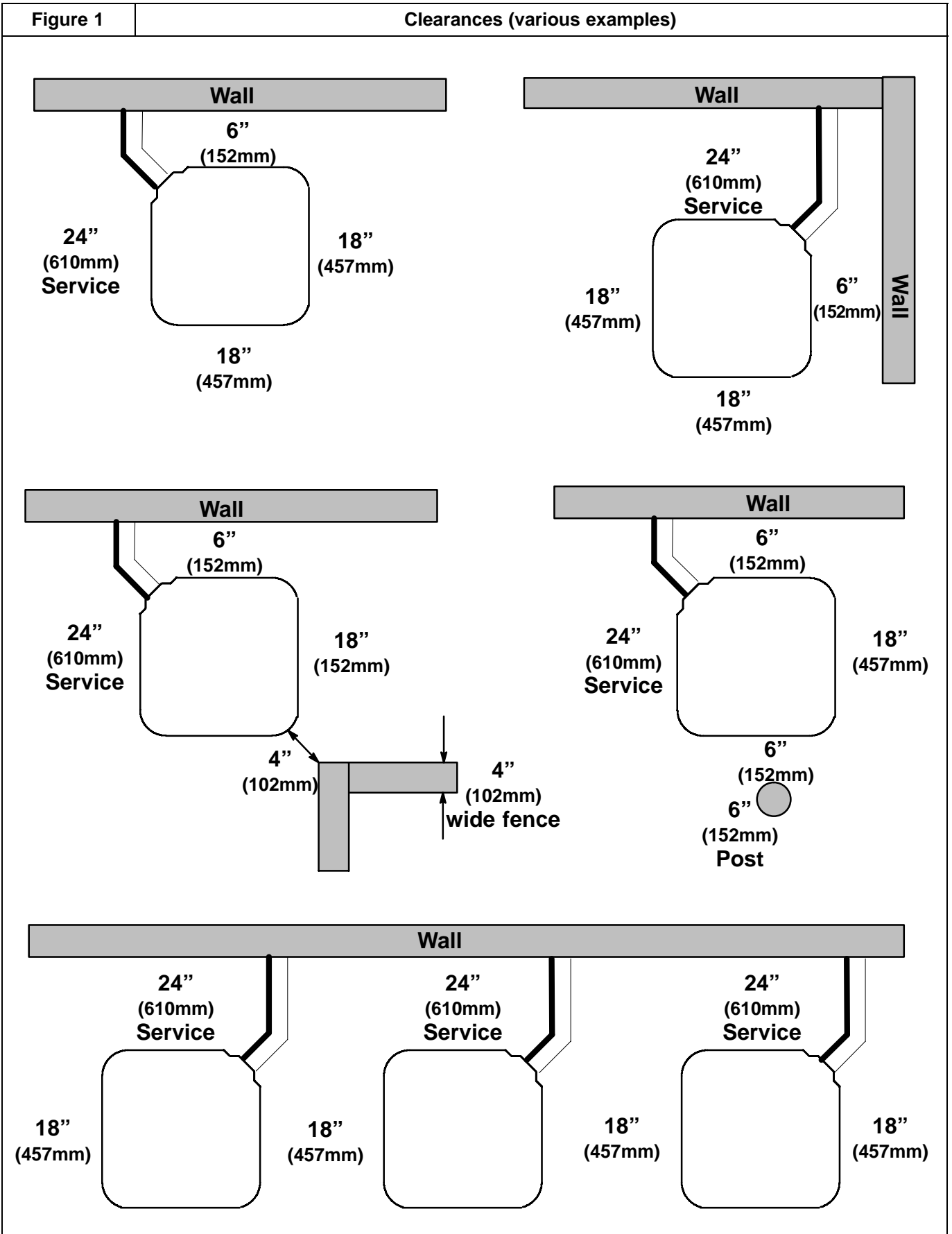

## UNIT SUPPORT

**NOTE:** Unit must be level  $\pm 2$  degrees { $\frac{3}{8}$  inch rise or fall per foot of run (10mm rise or fall per 305mm of run) } or compressor may not function properly.

### A. GROUND LEVEL INSTALLATION

The unit must be level and supported above grade by beams, platform, or a pad. Platform or pad can be of open or solid construction but should be of permanent materials such as concrete, bricks, blocks, steel, or pressure-treated timbers approved for ground contact. Soil conditions must be considered so that the platform or pad does not shift or settle and leave the unit partially supported. Minimum pad dimensions are shown in Figure 2.

If beams or an open platform are used for support, it is recommended that the soil be treated or area be grveled to reduce the growth of grasses and weeds.

To minimize vibration or noise transmission, it is recommended that supports not be in contact with the building structure. However, slabs on grade constructions with an extended pad are normally acceptable.

### B. ROOF TOP INSTALLATION

This type of installation is not recommended on wood frame structures where low noise levels are required.

Supporting structure or platform for the unit must be level. If installation is on a flat roof, locate unit minimum 6 inches above roof level.

Place the unit over one or more load bearing walls. If there are several units, mount them on platforms that are self-supporting and span several load bearing walls. These suggestions are to minimize noise and vibration transmission through the structure. If the structure is a home or apartment, avoid locating the unit over bedrooms or study.

**NOTE:** When unit is to be installed on a bonded guaranteed roof, a release must be obtained from the building owner to free the installer from all liabilities.

### C. FASTENING UNIT DOWN

If conditions or local codes require the unit be attached in place, remove the knockouts in the base pan and install tie down bolts through the holes (refer to Figure 2).

Contact local distributor for hurricane hold-down details and the P.E. (Professional Engineer) certification, when required.

**⚠ CAUTION**

**PROPERTY DAMAGE HAZARD**

**Failure to follow this caution may result in property damage.**

**Inadequate unit support may cause excessive vibration, noise, and/or stress on the refrigerant lines, leading to refrigerant line failure.**

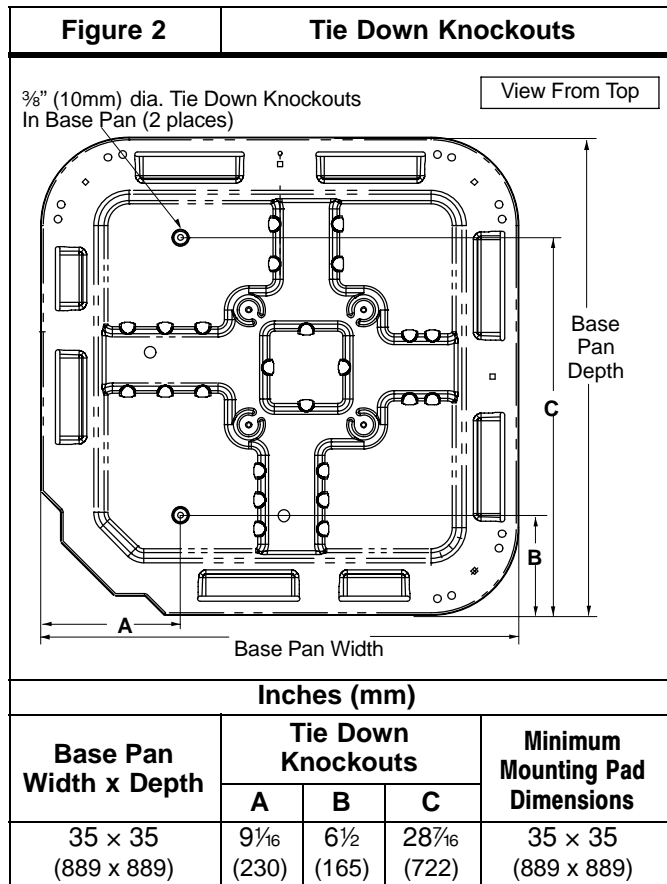

## REFRIGERATION SYSTEM

### A. COMPONENT MATCHES

Check to see that the proper system components are in place, especially the indoor coil.

R-410A outdoor units can only be used with R-410A specific indoor coils. If there is a refrigerant mis-match, consult the indoor coil manufacturer to determine if a refrigerant conversion kit is available for the indoor coil.

This outdoor unit is designed to achieve maximum efficiency when used with indoor coils that utilize a TXV refrigerant metering device. If any other type of metering device is installed on the indoor coil, consult the indoor coil manufacturer to determine if a TXV conversion kit is available.

When installing a TXV on an indoor coil, follow the instructions provided with the new TXV.

A typical TXV installation is shown in Figure 3.

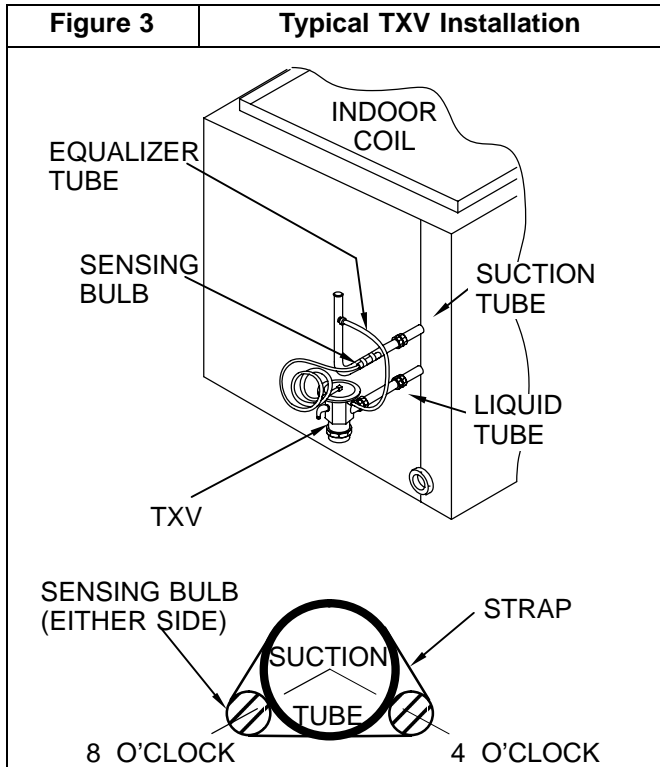

**B. REFRIGERANT LINE SETS**

The refrigerant line set must be properly sized to assure maximum efficiency and proper oil circulation.

**Refer to Product Specifications and Long Line Applications Guideline for line set sizing.**

If it is necessary to add refrigerant line in the field, use dehydrated or dry, sealed, deoxidized, copper refrigeration tubing. Do not use copper water pipe.

Do not remove rubber plugs or caps from copper tubing until connections are ready to be made.

Be extra careful when bending refrigeration tubing. Tubing can “kink” easily, and if this occurs, the entire length of tubing must be replaced.

**⚠ WARNING**

**PERSONAL INJURY HAZARD**

Failure to follow this warning could result in personal injury and/or death.

Relieve pressure and recover all refrigerant before servicing existing equipment, and before final unit disposal. Use all service ports and open all flow-control devices, including solenoid valves.

**C. ROUTING AND SUSPENDING REFRIGERANT LINES**

Run refrigerant lines as straight and direct as possible, avoiding unnecessary bends and turns. Always insulate the entire suction line. Both lines should be insulated when routed through an attic or when routed through an underground raceway.

When routing refrigerant lines through a foundation or wall, do not allow refrigerant lines to come in direct contact with the building structure. Make openings large enough so that lines can be wrapped with extra insulation. Fill all gaps with RTV caulk. This will prevent noise transmission between the tubing and the foundation or wall.

Along floor or ceiling joists, suspend refrigerant lines so that they do not contact the building structure, water pipes, or ductwork. Use insulated or suspension type hangers. Metal straps must be at least 1” wide (25mm) to avoid cutting into the tube insulation. Keep the liquid and suction lines separate. Refer to Figure 4.

**⚠ CAUTION**

**UNIT OPERATION HAZARD**

Failure to follow this caution may result in improper product operation.

Do not leave system open to atmosphere any longer than absolutely required for installation. Internal system components – especially refrigerant oils – are extremely susceptible to moisture contamination. Keep ends of tubing sealed during installation until the last possible moment.

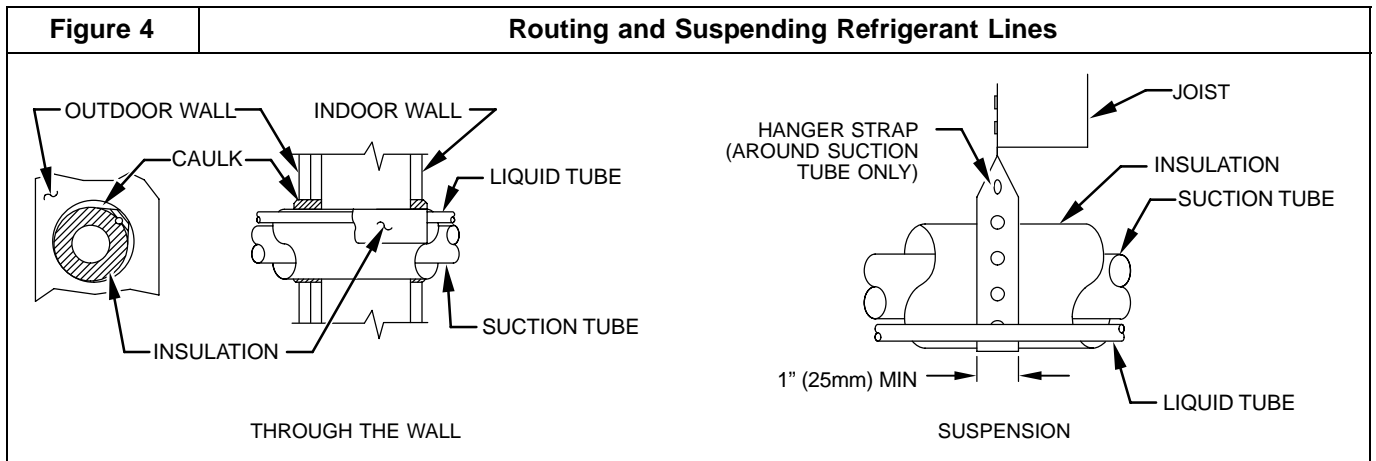

**⚠ CAUTION**

**UNIT OPERATION HAZARD**

Failure to follow this caution may result in improper product operation.

Do not bury more than 36" (1m) of line set underground. Refrigerant may migrate to cooler buried section during extended periods of unit shut-down, causing refrigerant slugging and possible compressor damage at start-up.

If ANY section of the line set is buried underground, provide a minimum 6" (152mm) vertical rise at the service valve.

**D. OUTDOOR UNIT HIGHER THAN INDOOR UNIT**

Proper oil return to the compressor should be maintained with suction gas velocity. If velocities drop below 1500 fpm (feet per minute), oil return will be decreased. To maintain suction gas velocity, do not upsize vertical suction risers.

**E. LIQUID LINE FILTER-DRIER**

Outdoor units are shipped with an appropriate filter-drier for installation in the liquid line. Leave the plugs in the tube ends until the filter-drier is installed. The optimal location for the filter-drier is close to the indoor coil. Install the filter-drier with the arrow pointing towards the indoor coil. Refer to Figure 5.

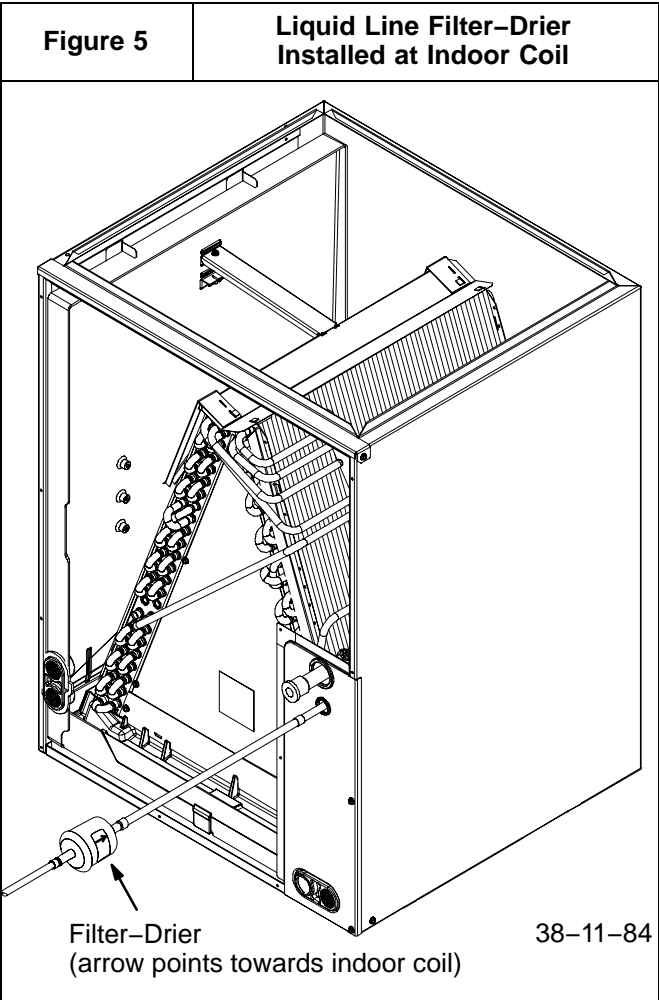

**F. SERVICE VALVES**

Service valves are closed and tube stubs are plugged from the factory. Outdoor units are shipped with a refrigerant charge sealed in the unit. Leave the service valves closed until all other refrigerant system work is complete or the charge will be lost. Leave the plugs in place until line set tubing is ready to be inserted.

Service valve bodies are brass and tube stubs are copper.

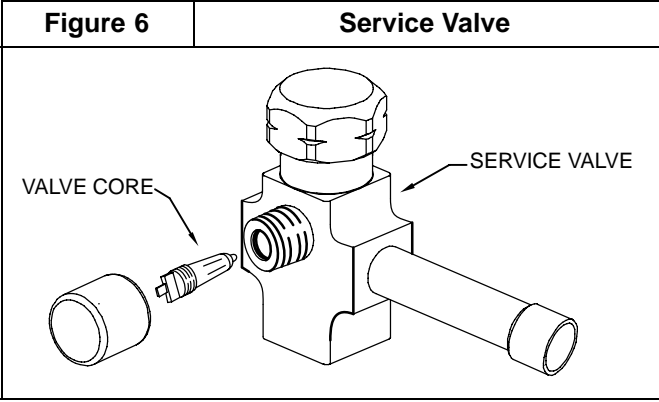

**G. BRAZING CONNECTIONS**

**NOTE:** Remove valve core from schrader port on both Service Valves BEFORE brazing. This helps prevent overheating and damage to valve seals (refer to Figure 6). Replace valve core when brazing is completed.

**⚠ WARNING**

**FIRE HAZARD**

Failure to follow this warning could result in personal injury, death, and/or property damage.

Refrigerant and oil mixture could ignite and burn as it escapes and contacts brazing torch. Make sure the refrigerant charge is properly removed from both the high and low sides of the system before brazing any component or lines.

Clean line set tube ends with emery cloth or steel brush. Remove any grit or debris.

Insert line set tube ends into service valve tube stubs.

Apply heat absorbing paste or heat sink product between service valve and joint. Wrap service valves with a heat sinking material such as a wet cloth.

Braze joints using a Sil-Fos or Phos-copper alloy.

**⚠ CAUTION**

**PRODUCT DAMAGE HAZARD**

Failure to follow this caution may result in product damage.

Braze with Sil-Fos or Phos-copper alloy on copper-to-copper joints and wrap a wet cloth around rear of fitting to prevent damage to TXV.

**H. EVACUATING LINE SET AND INDOOR COIL**

The unit is shipped with a factory refrigerant charge. The liquid line and suction line service valves have been closed after final testing at the factory. Do not disturb these valves until the line set and indoor coil have been evacuated and leak checked, or the charge in the unit may be lost.

**NOTE:** Do not use any portion of the factory charge for purging or leak testing. The factory charge is for filling the system only after a complete evacuation and leak check has been performed.

**⚠ CAUTION**

**PRODUCT DAMAGE HAZARD**

**Failure to follow this caution may result in product damage.**

**Never use the outdoor unit compressor as a vacuum pump. Doing so may damage the compressor.**

Line set and indoor coil should be evacuated using the recommended deep vacuum method of 500 microns. If deep vacuum equipment is not available, the alternate triple evacuation method may be used by following the specified procedure.

If vacuum must be interrupted during the evacuation procedure, always break vacuum with dry nitrogen.

**Deep Vacuum Method**

The deep vacuum method requires a vacuum pump capable of pulling a vacuum to 500 microns and a vacuum gauge capable of accurately measuring this vacuum level. The deep vacuum method is the most positive way of assuring a system is free of air and water.

Watch the vacuum gauge as the system is pulling down. The response of the gauge is an indicator of the condition of the system (refer to Figure 7).

With no leaks in the system, allow the vacuum pump to run for 30 minutes minimum at the deep vacuum level.

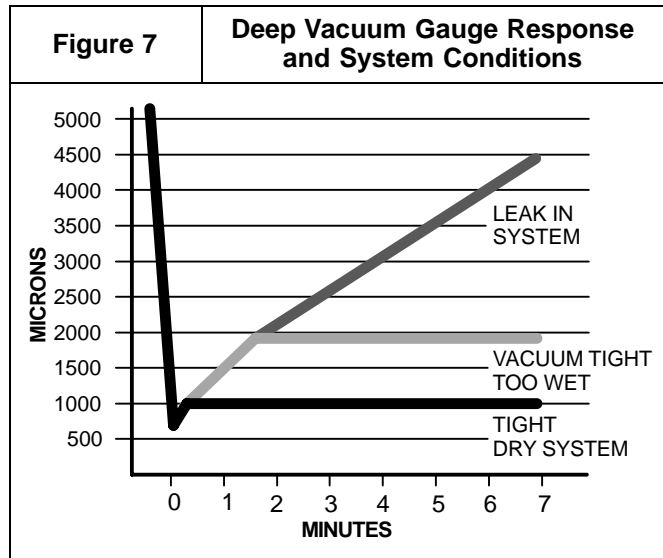

**Triple Evacuation Method**

The triple evacuation method should only be used when system does not contain any water in liquid form and vacuum pump is only capable of pulling down to 28 inches of mercury (711mm Hg). Refer to Fig. 8 and proceed as follows:

1. Pull system down to 28 inches of mercury (711mm Hg) and allow pump to continue operating for an additional 15 minutes.
2. Close manifold valves or valve at vacuum pump and shut off vacuum pump.
3. Connect a nitrogen cylinder and regulator to system and fill with nitrogen until system pressure is 2 psig.
4. Close nitrogen valve and allow system to stand for 1 hour. During this time, dry nitrogen will diffuse throughout the system absorbing moisture.
5. Repeat this procedure as indicated in Figure 8.
6. After the final evacuate sequence, confirm there are no leaks in the system. If a leak is found, repeat the entire process after repair is made.

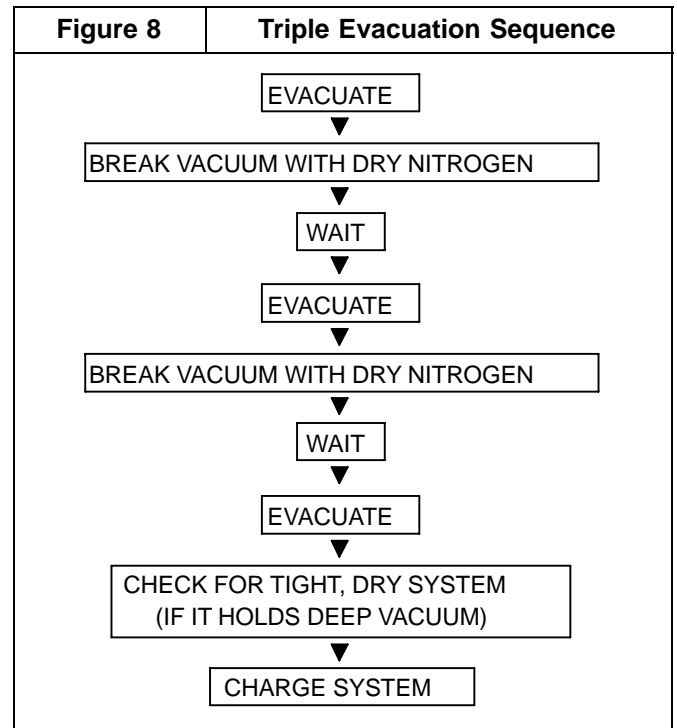

**I. OPENING SERVICE VALVES**

Outdoor units are shipped with a refrigerant charge sealed in the unit. Opening the service valves releases this charge into the system.

**NOTE:** Open the Suction service valve first. If the Liquid service valve is opened first, oil from the compressor may be drawn into the indoor coil TXV, restricting refrigerant flow and affecting operation of the system.

Remove Suction service valve cap and insert a hex wrench into the valve stem. Hold the valve body steady with an end-wrench and back out the stem by turning the hex wrench counterclockwise. Turn the stem until it just contacts the rolled lip of the valve body.

After the refrigerant charge has bled into the system, open the Liquid service valve.

**NOTE:** These are not back-seating valves. It is not necessary to force the stem tightly against the rolled lip.

The service valve cap is a primary seal for the valve and must be properly tightened to prevent leaks. Make sure cap is clean and apply refrigerant oil to threads and sealing surface on inside of cap.

Tighten cap finger tight and then tighten additional 1/6 of a turn (1 wrench flat) to properly seat the sealing surfaces.

**J. GAUGE PORTS**

Check for leaks at the schrader ports and tighten valve cores if necessary. Install plastic caps finger tight.

**ELECTRICAL WIRING**

**⚠ WARNING**

**ELECTRICAL SHOCK HAZARD**

Failure to follow this warning could result in personal injury or death.

Before installing, modifying or servicing system, turn OFF the main (remote) electrical disconnect device. There may be more than one disconnect device.

The supply voltage must be 208/230 volts (197 volt minimum to 253 volts maximum) 60 Hz single phase.

Outdoor units are approved for use with copper conductors only. Do not use aluminum wire.

Refer to unit rating plate for minimum circuit ampacity and circuit protection requirements.

**Grounding**

Permanently ground unit in accordance with the National Electrical Code and local codes or ordinances. Use a copper conductor of the correct size from the grounding lug in control box to a grounded connection in the service panel or a properly driven and electrically grounded ground rod.

**Wiring Connections**

Make all outdoor electrical supply (Line Voltage) connections with raintight conduit and fittings. Most codes require a disconnect switch outdoors within sight of the unit. Consult local codes for special requirements.

Route electrical supply (Line Voltage) wiring through knockout hole in bottom of Control Box. Connect wires to Contactor and Ground Lug according to Wiring Diagram on unit. Also refer to Figure 9.

Route thermostat wiring through rubber grommet in bottom of Control Box. Low voltage lead wires are provided in the control box for connection to thermostat wires (use wire nuts). Refer to Wiring Diagram on unit and Figure 10 for low voltage wiring examples.

**NOTE:** Use No. 18 AWG (American Wire Gage) color-coded, insulated (35° C minimum) wire. If thermostat is located more than 100 feet (30.5m) from unit as measured along the control voltage wires, use No. 16 AWG color-coded wires to avoid excessive voltage drop.

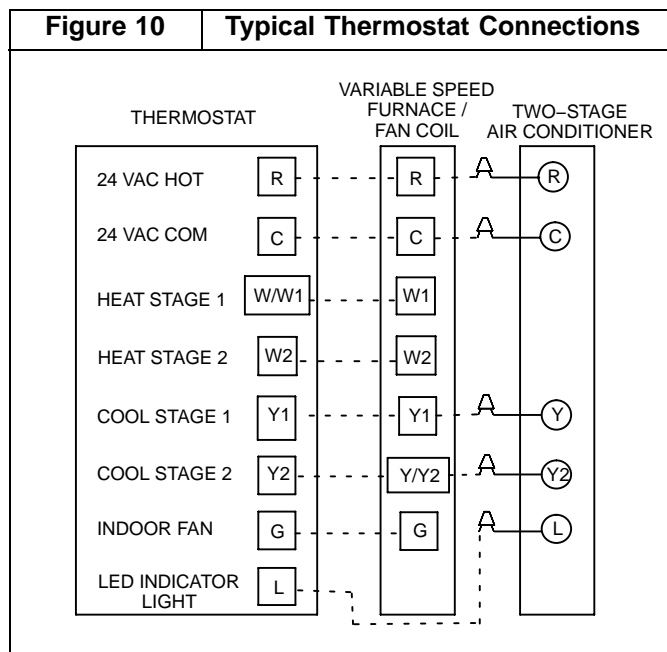
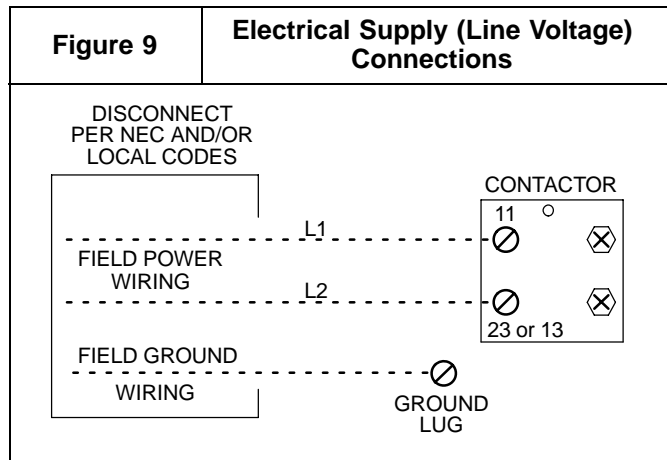

## AIRFLOW SELECTION

Two-stage compressor operation requires two different indoor airflow settings for proper operation. This outdoor unit is designed for use only with an indoor blower that can be configured for separate low-stage and high-stage airflow (CFM) levels. Refer to Product Specifications Sheets for recommended low-stage and high-stage indoor airflow values. Refer to indoor unit Installation Instructions to set the indoor blower for the proper low-stage and high-stage airflow values.

**NOTE:** Optimal comfort, efficiency, and reliability will only be achieved when the indoor airflow is properly set for both low-stage and high-stage operation.

## START-UP PROCEDURE

1. Set indoor thermostat selector switch to OFF.
2. Turn ON all electrical disconnect devices.
3. Unit has a crankcase heater. Energize the heater and wait 24 hours before proceeding.
4. Set indoor thermostat at desired temperature. Be sure setpoint is below indoor ambient temperature or thermostat will not call for cooling.
5. Set indoor thermostat selector switch to COOL. Operate unit for minimum 25 minutes, then check the system refrigerant charge.

## REFRIGERANT CHARGE

Outdoor units are shipped with a refrigerant charge to match a specific indoor coil and 15 feet (4.6m) of refrigerant line. If shorter or longer refrigerant lines or a different indoor coil are used, the charge will have to be adjusted.

For different line lengths, add or remove charge based on 0.6 ounces (17g) charge per foot (305mm) of difference. For example, a 25 foot (7.6m) line set is 10 feet (3m) longer than the specified 15 feet (4.6m). Add 0.6 ounces (17g) charge for each of the extra 10 feet (3m):

$10 \times 0.6 = 6.0$  ounces additional charge

$(3\text{m} \times 17\text{g}) = 51\text{g}$  additional charge

This outdoor unit is designed for use only with indoor coils that utilize a TXV refrigerant metering device. With an indoor TXV, use the subcooling method to make final charge adjustments:

**NOTE:** Only use subcooling charging method when

- outdoor ambient temperature is between 70°F and 100°F (21°C and 38°C)
- indoor temperature is between 70° and 80°F (21°C and 27°C)
- line set is less than 80 feet (24.4m).

1. Operate unit a minimum of 25 minutes in high stage before checking charge.

**NOTE:** Outdoor unit has a 2-speed fan motor. Motor will operate in low speed when outdoor ambient temperature is below 82°F (28°C). Pull one of the yellow low voltage wires off the fan control and the unit will default to high speed fan for servicing. Reconnect wire after servicing.

2. Measure liquid service valve pressure by attaching an accurate gauge to service port.
3. Measure liquid line temperature by attaching an accurate thermistor type sensor or electronic thermometer to liquid line near outdoor coil.
4. Refer to unit rating plate for required subcooling temperature.

5. Refer to Figure 11. Find the required liquid line temperature where the rating plate subcooling temperature intersects measured liquid service valve pressure.

6. If the measured liquid line temperature is higher than the chart number, add refrigerant to lower the measured temperature.

**NOTE:** When adding refrigerant, charge in liquid form, using a flow restricting device, into the suction port. If the measured liquid line temperature is lower than the chart number, reclaim refrigerant to raise the measured temperature.

Tolerance is  $\pm 3^\circ\text{F}$  ( $\pm 1.7^\circ\text{C}$ ).

Figure 11	Rating Plate (required) Subcooling Temperature °F (°C)											
	°F 6	(°C) 3	°F 8	(°C) 4	°F 10	(°C) 6	°F 12	(°C) 7	F 14	(°C) 8	F 16	(°C) 9
	R-410A Required Liquid Line Temperature °F (°C)											
251	78	26	76	24	74	23	72	22	70	21	68	20
259	80	27	78	26	76	24	74	23	72	22	70	21
266	82	28	80	27	78	26	76	24	74	23	72	22
274	84	29	82	28	80	27	78	26	76	24	74	23
283	86	30	84	29	82	28	80	27	78	26	76	24
291	88	31	86	30	84	29	82	28	80	27	78	26
299	90	32	88	31	86	30	84	29	82	28	80	27
308	92	33	90	32	88	31	86	30	84	29	82	28
317	94	34	92	33	90	32	88	31	86	30	84	29
326	96	36	94	34	92	33	90	32	88	31	86	30
335	98	37	96	36	94	34	92	33	90	32	88	31
345	100	38	98	37	96	36	94	34	92	33	90	32
364	104	40	102	39	100	38	98	37	96	36	94	34
374	106	41	104	40	102	39	100	38	98	37	96	36
384	108	42	106	41	104	40	102	39	100	38	98	37
395	110	43	108	42	106	41	104	40	102	39	100	38
406	112	44	110	43	108	42	106	41	104	40	102	39
416	114	46	112	44	110	43	108	42	106	41	104	40
427	116	47	114	46	112	44	110	43	108	42	106	41
439	118	48	116	47	114	46	112	44	110	43	108	42
450	120	49	118	48	116	47	114	46	112	44	110	43
462	122	50	120	49	118	48	116	47	114	46	112	44
474	124	51	122	50	120	49	118	48	116	47	114	46

## SEQUENCE OF OPERATION

With power supplied to indoor and outdoor units, transformer is energized.

**NOTE:** For low-stage operation, the outdoor unit Comfort Alert™ UltraTech™ is labeled Y and the indoor unit/thermostat is labeled Y1.

On a call for low-stage cooling, the thermostat energizes Y1 (low-stage compressor) and G. The call for Y1 energizes the contactor, starting the outdoor fan motor and low-stage compressor. The compressor operates at part load. The call for G energizes the indoor blower motor.

On a call for high-stage cooling, the thermostat energizes Y1, Y2 and G. The call for Y1 energizes the contactor, starting the outdoor fan motor and compressor. Five seconds after the compressor starts, Y2 energizes the compressor solenoid to load up the compressor to full capacity. The call for G energizes the indoor blower motor.

When the thermostat is satisfied, its contacts open, de-energizing contactor and blower. Compressor and motor stop.

**NOTE:** If indoor unit is equipped with a time-delay relay circuit, the blower runs an additional length of time to increase system efficiency.

## COMPRESSOR OPERATION

The basic scroll design has been modified with the addition of an internal unloading mechanism that opens a by-pass port in the first compression pocket, effectively reducing the displacement of the scroll. The opening and closing of the by-pass port is controlled by an internal electrically operated solenoid. The modulated scroll uses a single step of unloading to go from full capacity to approximately 67% capacity.

A single speed, high efficiency motor continues to run while the scroll modulates between the two capacity steps. Modulation is achieved by venting a portion of the gas in the first suction pocket back to the low side of the compressor, thereby reducing the effective displacement of the compressor.

Full capacity is achieved by blocking these vents, thus increasing the displacement to 100%. A DC solenoid in the compressor, controlled by a rectified external 24 volt AC signal, moves the slider ring that covers and uncovers these vents.

The vent covers are arranged in such a manner that the compressor operates at approximately 67% capacity when the solenoid is not energized and 100% capacity when the solenoid is energized. The loading and unloading of the two step scroll is done “on the fly” without shutting off the motor between steps.

**NOTE:** 67% compressor capacity translates to approximately 80% cooling or heating capacity at the indoor coil.

The compressor will always start unloaded and stay unloaded for five seconds even when the second stage of the thermostat is calling for more capacity (a starting advantage under low voltage conditions).

## TROUBLESHOOTING

Models are factory equipped with the Comfort Alert™ UltraTech™ Diagnostics device (refer to Figure 12) in the control box. Comfort Alert UltraTech provides compressor staging from low to high and high to low capacity. Comfort Alert UltraTech provides around-the-clock monitoring for common electrical problems, compressor defects, and broad system faults. If trouble is detected, an alert code is displayed with a flashing LED indicator. Alert codes are listed in Figure 13.

**The device is factory wired and requires no modification.** Low voltage lead wires are provided in the control box for connection to thermostat wires (use wire nuts).

The Comfort Alert UltraTech must be powered to properly stage compressor to high capacity. Energizing the Y (Y1) terminal operates the compressor in low stage. Both the Y (Y1) and Y2 terminals must be energized for high-stage operation.

The Comfort Alert UltraTech device operates by monitoring the compressor power leads and the thermostat demand signals Y (Y1) and Y2 terminals. It draws constant 24 VAC power at the R and C terminals.

When the compressor is operating in low stage (Y or Y1), the 24v DC compressor solenoid coil is de-energized. When the compressor is operating in high stage (Y or Y1 and Y2), the 24v DC solenoid coil is energized. The 24v DC plug that is connected to the compressor does NOT have an internal rectifier. **DO NOT INSTALL A PLUG WITH INTERNAL RECTIFIER.**

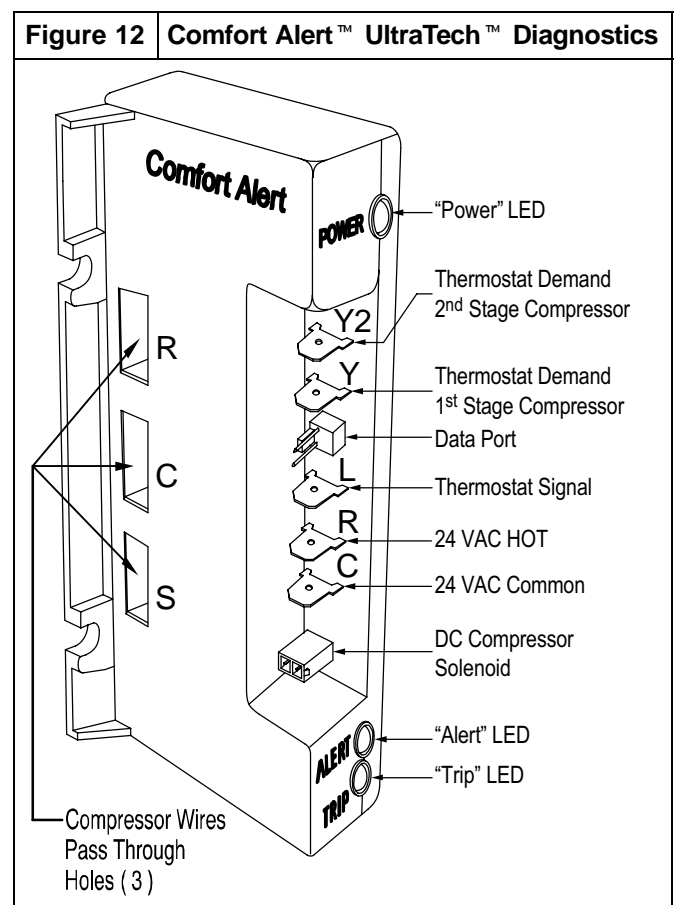

Two-Stage Compressor Resistance (winding resistance) at 70° F +/- 20° F (21°C +/- 11° C)				
Winding	*4A624	*4A836	*4A648	*4A660
Start (S-C)	1.40	1.29	1.52	0.60
Run (R-C)	1.32	0.89	0.64	0.49

**NOTE:** The rectifier for the DC solenoid is contained within the Comfort Alert UltraTech device. The plug at the compressor solenoid is an ordinary 2-wire plug. Never use a plug with internal rectifier with this system.

**NOTE:** The DC compressor solenoid plug that connects to the Comfort Alert UltraTech is polar dependent and should only be connected with the tabs aligned.

**Unloader Test Procedure with Comfort Alert™ Module**

The unloader is the compressor internal mechanism, controlled by the DC solenoid, that modulates between high and low stage.

If it is suspected that the unloader is not working, the following methods may be used to verify operation.

1. Operate the system and measure compressor amperage. Cycle the unloader on and off at ten plus second intervals by applying and removing Y2 voltage to the module. Wait five seconds after power is applied to Y2 before taking a reading. The compressor amperage should go up or down at least 25 percent.

2. If step one does not give the expected results, remove the solenoid plug from the compressor and, with the unit running and the thermostat calling for Y2 to be energized, test the voltage output at the plug with a DC voltmeter.

The reading here should be 4 to 18 volts. If NOT, unplug the harness from the module and check voltage at the "DC Sol" pins of the module. The module will not power the unloader solenoid if the compressor is not running or fault code 1 or 9 is active.

3. If the correct DC voltage is at the control circuit molded plug, measure the unloader coil resistance. The resistance should be 32 to 60 ohms depending on compressor temperature. If the coil resistance is infinity, much lower than 32 ohms, or is grounded, the compressor must be replaced.

## MAINTENANCE

### Condensate Drain

During the cooling season, check monthly for free flow of drainage and clean if necessary.

### Cleanliness

These tips will help keep the air conditioner looking better and working more efficiently:

1. Free flow of air is essential. Keep fences, shrubs, trash cans, and other obstructions at least 18 inches (457mm) from all coil inlets.
2. Keep the coil free of grass clippings, leaves, weeds, and other debris.  
**NOTE:** Coil may occasionally require cleaning with a liquid solution. The coil must be cold when cleaning. Use an alkaline based cleaner only. Cleaning a hot coil or using an acid based cleaner will remove the paint from the fins and may clog the coil.
3. Never use a weather cover over the outdoor unit unless it is a ventilated type or made of breathable fabric that will allow moisture to evaporate rapidly. A cover that holds moisture in the unit will cause more rust build-up and damage than normal exposure to weather.

Figure 13		
Comfort Alert™ UltraTech™ Diagnostics		
Status LED	Status LED Description	Status LED Troubleshooting Information
<b>Green “POWER”</b>	Module has power	Supply voltage is present at module terminals
<b>Red “TRIP”</b>	Thermostat demand signal Y is present, but the compressor is not running	<ol style="list-style-type: none"> <li>Compressor protector is open                             <ul style="list-style-type: none"> <li>Check for high head pressure</li> <li>Check compressor supply voltage</li> </ul> </li> <li>Outdoor unit power disconnect is open</li> <li>Compressor circuit breaker or fuse(s) is open</li> <li>Broken wire or connector is not making contact</li> <li>Compressor contactor has failed open</li> </ol>
<b>Yellow “ALERT”</b> Flash Code 1	<b>Long Run Time</b> Compressor is running extremely long run cycles (18 hours or more)	<ol style="list-style-type: none"> <li>Low refrigerant charge</li> <li>Evaporator blower is not running                             <ul style="list-style-type: none"> <li>Check blower relay coil and contacts</li> <li>Check blower motor for failure or blockage</li> <li>Check evaporator blower wiring and connectors</li> <li>Check indoor blower control board</li> <li>Check thermostat wiring for open circuit</li> </ul> </li> <li>Evaporator coil is frozen                             <ul style="list-style-type: none"> <li>Check for low suction pressure</li> <li>Check for excessively low thermostat setting</li> <li>Check evaporator airflow (coil blockages or return air filter)</li> <li>Check ductwork or registers for blockage</li> </ul> </li> <li>Faulty metering device                             <ul style="list-style-type: none"> <li>Check TXV bulb installation (size, location, and contact)</li> <li>Check if TXV is stuck closed or defective</li> </ul> </li> <li>Condenser coil is dirty</li> <li>Liquid line restriction (filter drier blocked)</li> <li>Compressor high-stage cooling wiring                             <ul style="list-style-type: none"> <li>Solenoid plug not connected / malfunction</li> <li>Comfort Alert™ failure</li> </ul> </li> <li>Thermostat is malfunctioning                             <ul style="list-style-type: none"> <li>Check thermostat sub-base or wiring for short circuit</li> <li>Check thermostat installation (location, level)</li> </ul> </li> </ol>
<b>Yellow “ALERT”</b> Flash Code 2	<b>Internal Protector Trip</b>	<ol style="list-style-type: none"> <li>The internal motor protector has opened                             <ul style="list-style-type: none"> <li>Wait for compressor to cool down, protector will close automatically</li> </ul> </li> </ol>
<b>Yellow “ALERT”</b> Flash Code 3	<b>Short Cycling</b> Compressor is running only briefly (1–3 minutes)	<ol style="list-style-type: none"> <li>Thermostat demand signal is intermittent</li> <li>High head pressure                             <ul style="list-style-type: none"> <li>Check high pressure switch</li> <li>Check if system is overcharged with refrigerant</li> <li>Check for non-condensable in system</li> </ul> </li> <li>Condenser coil poor air circulation (dirty, blocked, damaged)</li> <li>Condenser fan is not running                             <ul style="list-style-type: none"> <li>Check fan capacitor</li> <li>Check fan wiring and connectors</li> <li>Check fan motor for failure or blockage</li> </ul> </li> <li>Return air duct has substantial leakage</li> <li>Low pressure switch open, see Flash Code 1 information</li> </ol>
<b>Yellow “ALERT”</b> Flash Code 4	<b>Locked Rotor</b>	<ol style="list-style-type: none"> <li>Run capacitor has failed</li> <li>Low line voltage (contact utility if voltage at disconnect is low, below 187v)                             <ul style="list-style-type: none"> <li>Check wiring connections</li> </ul> </li> <li>Excessive liquid refrigerant in compressor</li> <li>Compressor bearings are seized</li> </ol>

– continued on next page –

Status LED	Status LED Description	Status LED Troubleshooting Information
<b>Yellow “ALERT”</b> Flash Code 5	<b>Open High Voltage Circuit</b>	<ol style="list-style-type: none"> <li>1. Outdoor unit power disconnect is open</li> <li>2. Compressor circuit breaker or fuse(s) is open</li> <li>3. Compressor contactor has failed open                             <ul style="list-style-type: none"> <li>• Check compressor contactor wiring and connections</li> <li>• Check for compressor contactor failure (burned, pitted, open)</li> <li>• Check wiring and connectors between supply and compressor</li> <li>• Check for low pilot voltage at compressor contactor coil</li> </ul> </li> <li>4. Open circuit in compressor supply wiring or connections</li> <li>5. Unusually long compressor protector reset time due to extreme ambient temperature</li> <li>6. Compressor windings are damaged                             <ul style="list-style-type: none"> <li>• Check compressor motor winding resistance</li> </ul> </li> </ol>
<b>Yellow “ALERT”</b> Flash Code 6	<b>Open Start Circuit</b> Current only in run circuit	<ol style="list-style-type: none"> <li>1. Run capacitor has failed</li> <li>2. Open circuit in compressor start wiring or connections                             <ul style="list-style-type: none"> <li>• Check wiring and connectors between supply and the compressor “S” terminal</li> </ul> </li> <li>3. Compressor start winding is damaged                             <ul style="list-style-type: none"> <li>• Check compressor motor winding resistance</li> </ul> </li> </ol>
<b>Yellow “ALERT”</b> Flash Code 7	<b>Open Run Circuit</b> Current only in start circuit	<ol style="list-style-type: none"> <li>1. Open circuit in compressor run wiring or connections                             <ul style="list-style-type: none"> <li>• Check wiring and connectors between supply and the compressor “R” terminal</li> </ul> </li> <li>2. Compressor run winding is damaged                             <ul style="list-style-type: none"> <li>• Check compressor motor winding resistance</li> </ul> </li> </ol>
<b>Yellow “ALERT”</b> Flash Code 8	<b>Welded Contactor</b> Compressor always runs continuous operation	<ol style="list-style-type: none"> <li>1. Compressor contactor has failed closed</li> <li>2. Thermostat demand signal not connected to module</li> </ol>
<b>Yellow “ALERT”</b> Flash Code 9	<b>Low Voltage</b> Control circuit < 17 VAC	<ol style="list-style-type: none"> <li>1. Control circuit transformer is overloaded</li> <li>2. Low line voltage (contact utility if voltage at disconnect is low)                             <ul style="list-style-type: none"> <li>• Check wiring connections</li> </ul> </li> </ol>

- Flash Code number corresponds to a number of LED flashes, followed by a pause and then repeated.
- TRIP and ALERT LEDs flashing at same time means control circuit voltage is too low for operation.
- Reset ALERT Flash code by removing 24VAC power from module (R terminal).
- Last stored ALERT Flash code is displayed for one minute after module is powered on. The code must flash a total of one minute before it will clear.

## R-410A QUICK REFERENCE GUIDE

---

- R-410A refrigerant operates at 50% – 70% higher pressures than R-22. Be sure that servicing equipment and replacement components are designed to operate with R-410A.
- R-410A refrigerant cylinders are rose colored.
- Recovery cylinder service pressure rating must be 400 psig, DOT 4BA400 or DOT BW400.
- R-410A systems should be charged with liquid refrigerant. Use a commercial type metering device in the manifold hose.
- Manifold sets should be 750 psig high-side and 200 psig low-side with 520 psig low-side retard.
- Use hoses with 750 psig service pressure rating.
- Leak detectors should be designed to detect HFC refrigerant.
- R-410A, as with other HFC refrigerants, is only compatible with POE oils.
- Vacuum pumps will not remove moisture from oil.
- Do not use liquid line filter-driers with rated working pressures less than 600 psig.
- Do not install a suction line filter-drier in liquid line.
- POE oils absorb moisture rapidly. Do not expose oil to atmosphere.
- POE oils may cause damage to certain plastics and roofing materials.
- Wrap all filter-driers and service valves with wet cloth when brazing.
- A liquid line filter-drier is required on every unit.
- Do not use with an R-22 TXV.
- If indoor unit is equipped with an R-22 TXV, it must be changed to an R-410A TXV.
- Never open system to atmosphere while it is under a vacuum.
- When system must be opened for service, break vacuum with dry nitrogen and replace all filter-driers.
- Do not vent R-410A into the atmosphere.
- Do not use capillary tube indoor coils.
- Observe all **WARNINGS**, **CAUTIONS**, **NOTES**, and **bold** text.