



# FVM Product Specifications

## VARIABLE SPEED FAN COILS

### ALL MODELS

- 2, 3, 4, and 5 Tons
- Supports two-stage outdoor units
- Available for R-22 or Environmentally Sound R-410A systems
- Bolt-on, hard shut-off TXV metering device factory installed on all models
- Copper tube / aluminum fin coil
- Sweat connections
- Primary and secondary drain fittings with brass inserts
- Time delay relay (TDR)
- Field installed heater packages from 5 kW – 30 kW available separately
- HUD approved for manufactured housing
- 208/230-1-60 supply voltage
- Multiposition installation – upflow or horizontal left standard, horizontal right with minor modification (field convertible to downflow with accessory kits)
- Filter factory supplied
- Heat staging option
- Humidifier/Humidistat terminals
- 1 inch thick insulation with R value of 4.2

### PERFORMANCE

- High Efficiency variable speed Electronically Commutated Motor “ECM” on all models
- Adjustable cooling and heating ON/OFF delay
- Heat Pump Comfort option to provide higher than normal heating air delivery temperature
- Units tested and certified by manufacturer to achieve a 2% or less leakage rate at 1.0 inch water column

### EASY TO INSTALL AND SERVICE

- Multiple electrical entry locations
- TXV and manifold positioned to the side for easier cleaning
- Zero clearance without heaters



Rated in accordance with ARI Standard 210 and/or 240. Certification applies only when used with proper components as listed with ARI.



Model Series	Nominal BTU	Tons	CFM Range		Dimensions H x W x D (in)	Filter Size (in)	Unit Wt. (lbs)	Ship Wt. (lbs)
			Low	High				
FVM*X2400A	24,000	2	350	1200	42 <sup>1</sup> / <sub>16</sub> x 17 <sup>5</sup> / <sub>8</sub> x 22 <sup>1</sup> / <sub>16</sub>	16 <sup>3</sup> / <sub>8</sub> x 21 <sup>1</sup> / <sub>2</sub>	124	130
FVM*X3600A	36,000	3	415	1400	53 <sup>7</sup> / <sub>16</sub> x 21 <sup>1</sup> / <sub>8</sub> x 22 <sup>1</sup> / <sub>16</sub>	19 <sup>7</sup> / <sub>8</sub> x 21 <sup>1</sup> / <sub>2</sub>	142	149
FVM*X4800A	48,000	4	425	1600			159	167
FVM*X6000A	60,000	5	540	2000	59 <sup>3</sup> / <sub>16</sub> x 24 <sup>1</sup> / <sub>16</sub> x 22 <sup>1</sup> / <sub>16</sub>	23 <sup>5</sup> / <sub>16</sub> x 21 <sup>1</sup> / <sub>2</sub>	192	202

\* = 2 (R-22) or 4 (R-410A)

Specifications are subject to change without notice

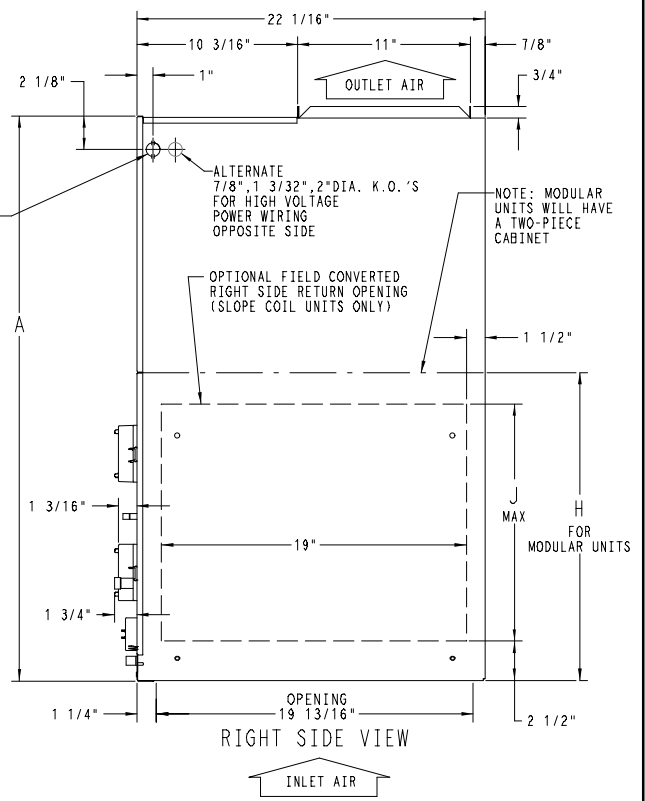
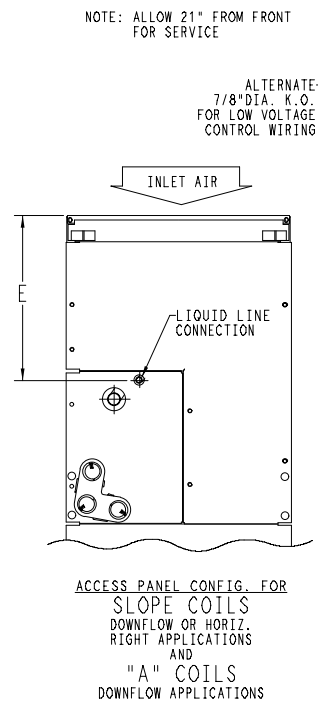
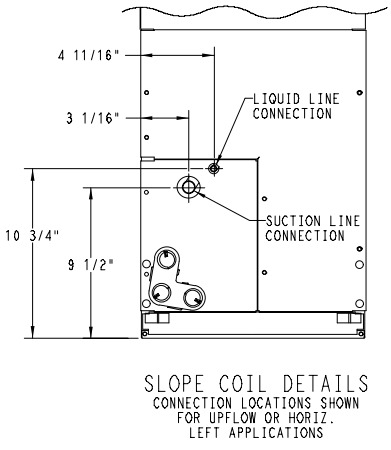
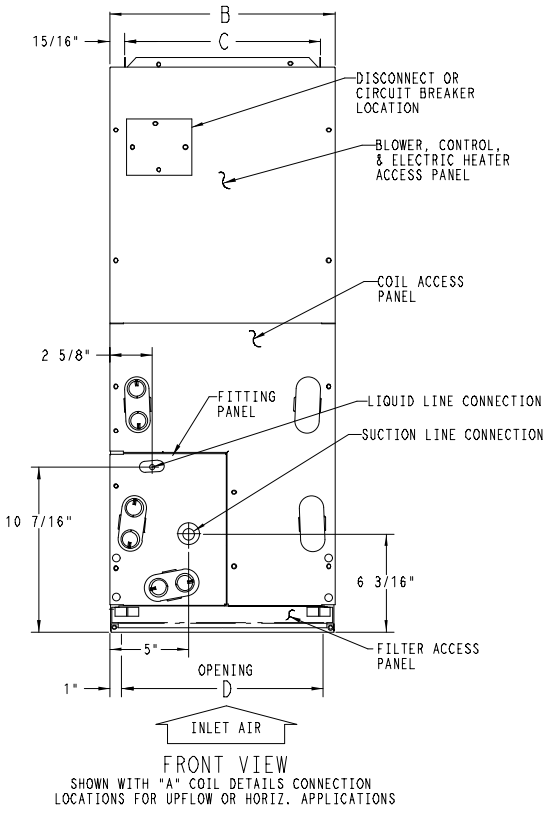
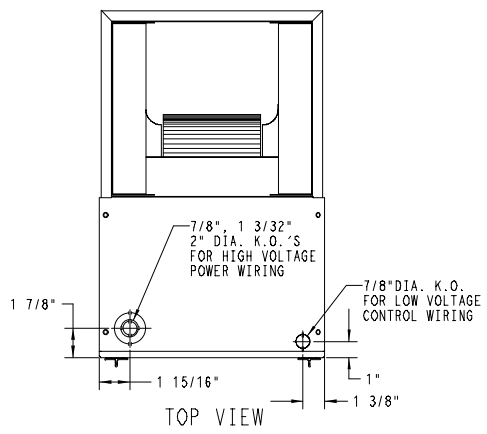

NOTES:  
1. CONDENSATE PAN DRAIN CAPS NOT SHOWN FOR CLARITY.

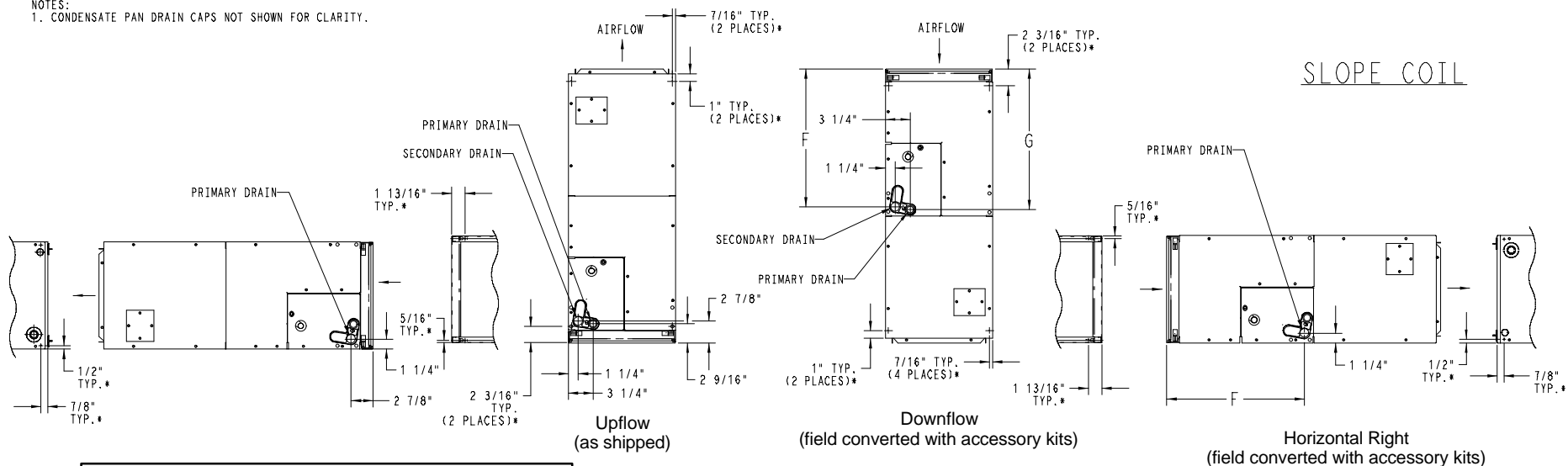

\* HORIZONTAL MOUNT LOCATIONS - DIMPLES PROVIDED IN TOP PANEL, AND BACK OF CABINET. IN CABINET BOTTOM, HOLES PROVIDED .136" DIA. HORIZONTAL HANGING HARDWARE TO BE FIELD SUPPLIED.

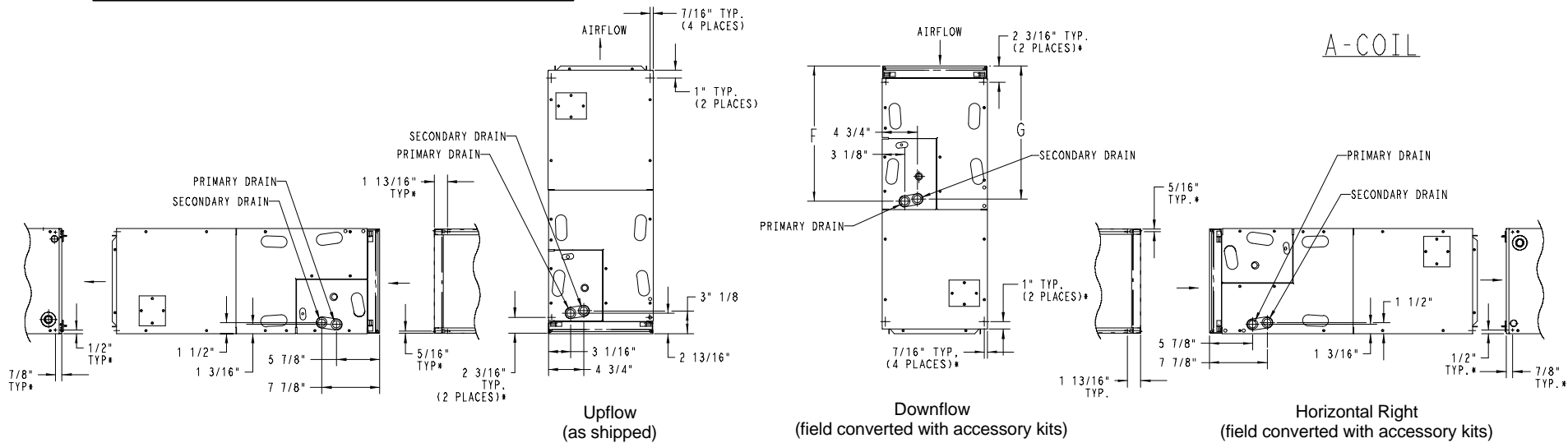

**DIMENSIONAL DATA (refer to drawings on pages 2 & 3)**

Model * = 2 or 4	Size (tons)	all dimensions inches									Coil Type
		A	B	C	D	E	F	G	H	J	
FVM*X2400A	2	42 <sup>11</sup> / <sub>16</sub>	17 <sup>5</sup> / <sub>8</sub>	15 <sup>3</sup> / <sub>4</sub>	15 <sup>5</sup> / <sub>8</sub>	15 <sup>3</sup> / <sub>4</sub>	18 <sup>9</sup> / <sub>16</sub>	18 <sup>1</sup> / <sub>4</sub>	N/A	N/A	"A"
FVM*X3600A	3	53 <sup>7</sup> / <sub>16</sub>	21 <sup>1</sup> / <sub>8</sub>	19 <sup>1</sup> / <sub>4</sub>	19 <sup>1</sup> / <sub>8</sub>	19 <sup>3</sup> / <sub>16</sub>	26 <sup>15</sup> / <sub>16</sub>	27 <sup>1</sup> / <sub>2</sub>	N/A	19	Slope
FVM*X4800A	4	53 <sup>7</sup> / <sub>16</sub>	21 <sup>1</sup> / <sub>8</sub>	19 <sup>1</sup> / <sub>4</sub>	19 <sup>1</sup> / <sub>8</sub>	19 <sup>1</sup> / <sub>2</sub>	27 <sup>1</sup> / <sub>4</sub>	26 <sup>15</sup> / <sub>16</sub>	28 <sup>5</sup> / <sub>16</sub>	N/A	"A"
FVM*X6000A	5	59 <sup>3</sup> / <sub>16</sub>	24 <sup>11</sup> / <sub>16</sub>	22 <sup>3</sup> / <sub>4</sub>	22 <sup>11</sup> / <sub>16</sub>	25 <sup>1</sup> / <sub>4</sub>	32 <sup>15</sup> / <sub>16</sub>	32 <sup>5</sup> / <sub>8</sub>	34 <sup>1</sup> / <sub>16</sub>	N/A	"A"

**PHYSICAL DATA**

FVM	Model Size			
	2400	3600	4800	6000
<b>TXV factory installed, hard shut-off, bi-flow type for heat pump application</b>				
FVM2X	3 ton	5 ton		6 ton
FVM4X	2 ton	3 ton	4 ton	
<b>Blower Data</b>				
Motor type	High Efficiency Variable Speed ECM motor			
HP	1/2	1/2	1/2	3/4
<b>Filter Data</b>				
Filter Size	16 <sup>3</sup> / <sub>8</sub> x 21 <sup>1</sup> / <sub>2</sub>	19 <sup>7</sup> / <sub>8</sub> x 21 <sup>1</sup> / <sub>2</sub>		23 <sup>5</sup> / <sub>16</sub> x 21 <sup>1</sup> / <sub>2</sub>
<b>Coil Data (all coils are 3 row, 14<sup>1</sup>/<sub>2</sub> fins per inch, wavy lanced bare aluminum fin)</b>				
Face Area (ft <sup>2</sup> )	3.46	3.46	5.93	7.42
<b>Refrigerant Line Connections (sweat)</b>				
Liquid (inch)	3/8	3/8	3/8	3/8
Suction (inch)	3/4	7/8	7/8	7/8

**ELECTRICAL DATA, FAN COIL ONLY WITHOUT ELECTRIC HEAT**

Model (* = 2 or 4)	208/230V, single phase, 60 Hz		
	Motor Full Load Amps (FLA)	Minimum Circuit Ampacity (MCA)	Maximum Fuse/Ckt Bkr Amps (Max OverCurrent Protection – MOCP)
FVM*X2400	4.3	5.4	15
FVM*X3600	4.3	5.4	15
FVM*X4800	4.3	5.4	15
FVM*X6000	6.8	8.5	15

**AIRFLOW PERFORMANCE – CFM RANGE**

Fan Coil Size	Use with Outdoor Unit Size	CFM Range
FVM*X2400	18, 24, 30, 36	350–1200
FVM*X3600	24, 30, 36, 42	415–1400
FVM*X4800	30, 36, 42, 48	425–1600
FVM*X6000	36, 42, 48, 60	540–2000

AIRFLOW PERFORMANCE – CFM IN COOLING MODE (A/C or Heat Pump)										
Unit Size	Outdoor Unit Size	Single Stage Cooling		Two-Stage Cooling				Fan Only		
		Nominal	Dehum	High		Low				
				Nominal	Dehum	Nominal	Dehum	Nominal	Dehum	Low
2400	18	525	420	Two-Stage outdoor unit not offered				350	420	525
	24	700	560	700	560	560	450	350	560	700
	30	875	700	Two-Stage outdoor unit not offered				440	700	875
	36	1050	840	1050	840	840	670	525	840	1050
3600	24	700	560	700	560	560	450	415	560	700
	30	875	700	Two-Stage outdoor unit not offered				440	700	875
	36	1050	840	1050	840	840	670	525	840	1050
	42	1225	980	Two-Stage outdoor unit not offered				615	980	1225
4800	30	875	700	Two-Stage outdoor unit not offered				440	700	875
	36	1050	840	1050	840	840	670	525	840	1050
	42	1225	980	Two-Stage outdoor unit not offered				615	980	1225
	48	1400	1120	1400	1120	1120	900	700	1120	1400
6000	36	1050	840	1050	840	840	670	540	840	1050
	42	1225	980	Two-Stage outdoor unit not offered				615	980	1225
	48	1400	1120	1400	1120	1120	900	700	1120	1400
	60	1750	1400	1750	1400	1400	1120	875	1400	1750

NOTES:

1. The above airflows result with the AC/HP CFM ADJUST select jumper set on NOM.
2. Airflow can be adjusted +15% or -10% by selecting Hi or Lo respectively for all modes except fan only.
3. Dry coil at 230 volts and with 10kW heater and filter installed.
4. Airflows shown are valid for systems with total external static pressure between 0.1 and 0.7 inches water column.

AIRFLOW PERFORMANCE – CFM IN HEAT PUMP HEATING MODE ONLY										
Unit Size	Outdoor Unit Size	Single Stage HP Heating		Two-Stage HP Heating				Fan Only		
		Comfort	Eff	High		Low				
				Comfort	Eff	Comfort	Eff	Comfort	Eff	Low
2400	18	475	525	Two-Stage outdoor unit not offered				350	380	475
	24	630	700	630	700	505	560	350	505	630
	30	785	875	Two-Stage outdoor unit not offered				440	630	785
	36	945	1050	945	1050	755	840	525	755	945
3600	24	630	700	630	700	505	560	415	505	630
	30	785	875	Two-Stage outdoor unit not offered				440	630	785
	36	945	1050	945	1050	755	840	525	755	945
	42	1100	1225	Two-Stage outdoor unit not offered				615	880	1100
4800	30	785	875	Two-Stage outdoor unit not offered				440	630	785
	36	945	1050	945	1050	755	840	525	755	945
	42	1100	1225	Two-Stage outdoor unit not offered				615	880	1100
	48	1260	1400	1260	1400	1010	1120	700	1010	1260
6000	36	945	1050	945	1050	755	840	540	755	945
	42	1100	1225	Two-Stage outdoor unit not offered				615	880	1100
	48	1260	1400	1260	1400	1010	1120	700	1010	1260
	60	1575	1750	1575	1750	1260	1400	875	1260	1575

NOTES:

1. The above airflows result with the AC/HP CFM ADJUST select jumper set on NOM.
2. Airflow can be adjusted +15% or -10% by selecting Hi or Lo respectively for all modes except fan only.
3. Dry coil at 230 volts and with 10kW heater and filter installed.
4. Airflows shown are valid for systems with total external static pressure between 0.1 and 0.7 inches water column.

ELECTRIC HEATERS		
Part Number	Description	Use with Model Sizes
EHK05AKN	5 kW, single phase, no internal circuit protection	ALL
EHK05AKB	5 kW, single phase, with circuit breakers	ALL
EHK07AKN	8 kW, single phase, no internal circuit protection	ALL
EHK07AKB	8 kW, single phase, with circuit breakers	ALL
EHK09AKCN	9 kW, supplied as single phase, field convertible to 3-phase, no internal circuit protection	3600, 4800, 6000
EHK10AKN	10 kW, single phase, no internal circuit protection	ALL
EHK10AKB	10 kW, single phase, with circuit breakers	ALL
EHK15AKF	15 kW, single phase, with fuses	ALL
EHK15AKB	15 kW, single phase, with circuit breakers	ALL†
EHK15AHN	15 kW, 3-phase, no internal circuit protection	ALL†
EHK18AHN	18 kW, 3-phase, no internal circuit protection	4800, 6000
EHK20AKF	20 kW, single phase, with fuses	ALL†
EHK20AKB	20 kW, single phase, with circuit breakers	ALL†
EHK25AHCF	24 kW, supplied as 3-phase, field convertible to single phase, with fuses	4800, 6000
EHK30AHCF	30 kW, supplied as 3-phase, field convertible to single phase, with fuses	4800, 6000

† 15kW & 20kW are not recommended for specific heat pump applications, see AIRFLOW DELIVERY (CFM)

AIRFLOW DELIVERY (CFM)													
FVM Model Size	Outdoor Unit Capacity (BTUH)	Electric Heater kW Range											
		0 – 5			0 – 10			0 – 15			0 – 20		
		LO	NOM	HI	LO	NOM	HI	LO	NOM	HI	LO	NOM	HI
2400	18	625	625	625	675	675	675	*	*	*	*	*	*
	24	650	725	835	*	725	835	875	875	875	*	*	*
	30	815	905	1040	*	905	1040	900	900	1040	1100	1100	1100
	36	980	1085	1250	980	1085	1250	980	1085	1250	1100	1100	1250
3600	24	675	725	835	875	875	*	*	*	*	*	*	*
	30	815	905	1040	875	905	1040	1100	1100	1100	*	*	*
	36	980	1085	1250	980	1085	1250	1100	1100	1250	1225	1225	1250
	42	1140	1270	1460	1140	1270	1460	1140	1270	1460	1225	1270	1460
		0 – 10			0 – 15			0 – 20			0 – 30		
4800	30	975	975	1040	1100	1100	1100	*	*	*	*	*	*
	36	980	1085	1250	1100	1100	1250	1250	1250	1250	*	*	*
	42	1140	1270	1460	1140	1270	1460	1250	1270	1460	*	*	*
	48	1305	1450	1665	1305	1450	1665	1305	1450	1665	1500	1500	1665
6000	36	1100	1100	1250	1350	1350	1350	*	*	*	*	*	*
	42	1140	1270	1460	1350	1350	1460	1525	1525	1525	*	*	*
	48	1305	1450	1665	1350	1450	1665	1525	1525	1665	1750	1750	1750
	60	1630	1810	2085	1630	1810	2085	1630	1810	2085	1750	1810	2085

\* Airflow not recommended for heater/system size

NOTE: LO, NOM, and HI refer to AC/HP CFM ADJUST selection on the control board.

HEAT PUMP MINIMUM CFM WHEN USING ELECTRIC HEAT (CFM)						
FVM Model Size	Outdoor Unit Size	Heater Size kW				
		5	8, 9, 10	15	18, 20	24, 30
2400	18	625	625	--	--	--
	24	650	725	875	--	--
	30	800	875	875	1040	--
	36	970	970	970	1040	--
3600	24	675	875	--	--	--
	30	800	875	1100	1150	--
	36	975	975	1100	1225	--
	42	1125	1125	1125	1225	--
4800	30	800	875	875	1150	--
	36	975	975	1100	1225	--
	42	1125	1125	1125	1225	--
	48	1305	1305	1305	1305	1400
6000	36	1100	1100	1350	1350	--
	42	1125	1125	1350	1350	--
	48	1300	1300	1350	1465	1750
	60	1625	1625	1625	1750	1750

A/C MINIMUM CFM WHEN USING ELECTRIC HEAT (CFM)						
FVM Model Size		Heater Size kW				
		5	8, 9, 10	15	18, 20	24, 30
2400	Heater Only	625	625	725	875	--
3600		675	700	850	1050	--
4800		675	700	850	1050	1400
6000		1050	1050	1050	1050	1750

NOTES:

1. Heater Only–Air conditioner with electric heater application.
2. These airflows are minimum acceptable airflows as UL listed. Actual airflow delivered will be per airflow delivery chart for Electric Heating Modes.

ACCESSORIES		
Description	Part Number	Use with models FVM models
Disconnect Kit	EBAC01DSC	use with All Heaters 5 kW thru 10 kW
Downflow Base Kit	EBAC02NCB	2400
	EBAC03NCB	3600, 4800
	EBAC04NCB	6000
Downflow Conversion Kit – Slope Coil	EBAC01DFS	3600
Downflow Conversion Kit – “A” Coil	EBAC02DFA	2400, 4800, 6000
Single Point Wiring Kit	EBAC01SPK	only for use with 15 kW & 20 kW fused heaters
Single Point Wiring Kit – Square D® Jumper Bar Assembly	QOU14100JBAF (Available through Square D only)	Only for use with EHK15AKB and EHK20AKB breaker heaters
Permanent Filter Kit (box of 12)	EBAC01FKM	2400
	EBAC01FKL	3600, 4800
	EBAC01FKX	6000
No Heat (Plug) Kit (box of 6)	EBAC01PLG	ALL (Factory Installed)
PVC Condensate Trap Kit (box of 50)	EBAC01CTK	ALL
Horizontal/Downflow Gasket Kit	EBAC01GSK	ALL (required for horizontal right and downflow)

**TABLE 3 - ELECTRIC HEATER ELECTRICAL DATA**

Heater Model	Heater kW		Phase	Internal Circuit Protection	Heater Amps 208/230V			Branch Circuit 208/230V					
								Minimum Circuit Ampacity (MCA) ☆			Max Fuse/Ckt Bkr Amps (Max OverCurrent Protection)		
	230V	208V			Single Circuit	Dual Circuit		Single Circuit	Dual Circuit		Single Circuit	Dual Circuit	
						L1, L2	L3, L4		L1, L2	L3, L4		L1, L2	L3, L4
EHK05AKN*	5	3.8	1	None	18.1 / 20.0	-	-	26.0 / 28.4	-	-	30 / 30	-	-
EHK05AKN**	5	3.8	1	None	18.1 / 20.0	-	-	31.2 / 33.5	-	-	35 / 35	-	-
EHK05AKB*	5	3.8	1	Ckt Bkr	18.1 / 20.0	-	-	26.0 / 28.4	-	-	30 / 30	-	-
EHK05AKB**	5	3.8	1	Ckt Bkr	18.1 / 20.0	-	-	31.2 / 33.5	-	-	35 / 35	-	-
EHK07AKN	8	6.0	1	None	28.9 / 32.0	-	-	44.7 / 48.5	-	-	45 / 50	-	-
EHK07AKB	8	6.0	1	Ckt Bkr	28.9 / 32.0	-	-	44.7 / 48.5	-	-	45 / 50	-	-
EHK09AKCN†	9	6.8	1	None	32.8 / 36.0	-	-	49.5 / 53.5	-	-	50 / 60	-	-
			3	None	18.8 / 20.8	-	-	32.0 / 34.5	-	-	35 / 35	-	-
EHK10AKN	10	7.5	1	None	36.2 / 40.0	-	-	53.8 / 58.5	-	-	60 / 60	-	-
EHK10AKB	10	7.5	1	Ckt Bkr	36.2 / 40.0	-	-	53.8 / 58.5	-	-	60 / 60	-	-
EHK15AKF	15	11.3	1	Fuse	54.2 / 59.9	36.2 / 40.0	18.1 / 20.0	76.3 / 83.4	53.8 / 58.5	22.7 / 25.0	80 / 90	60 / 60	25 / 25
EHK15AKB	15	11.3	1	Ckt Bkr	-	36.2 / 40.0	18.1 / 20.0	-	53.8 / 58.5	22.7 / 25.0	-	60 / 60	25 / 25
EHK15AHN	15	11.3	3	None	31.3 / 34.6	-	-	47.7 / 51.8	-	-	50 / 60	-	-
EHK18AHN	18	13.5	3	None	37.6 / 41.5	-	-	55.5 / 60.4	-	-	60 / 70	-	-
EHK20AKF	20	15.0	1	Fuse	72.3 / 79.9	36.2 / 40.0	36.2 / 40.0	98.9 / 108.4	53.8 / 58.5	45.3 / 50.0	100 / 110	60 / 60	50 / 50
EHK20AKB	20	15.0	1	Ckt Bkr	-	36.2 / 40.0	36.2 / 40.0	-	53.8 / 58.5	45.3 / 50.0	-	60 / 60	50 / 50
EHK25AHCF‡	24	18.0	3	Fuse	50.1 / 55.4	-	-	71.2 / 77.8	-	-	80 / 80	-	-
			1	Fuse	86.7 / 95.5	-	-	116.9 / 127.9	-	-	125 / 150	-	-
EHK30AHCF‡	30	22.5	3	Fuse	62.6 / 69.2	-	-	86.8 / 95.0	-	-	90 / 100	-	-
			1	Fuse	109 / 120	-	-	144.8 / 158.5	-	-	150 / 175	-	-

**TABLE 4 - FIELD MULTIPOINT WIRING OR 24 AND 30 KW SINGLE PHASE**

Heater Model	Heater kW		P H A S E	Heater Amps 208/230V			Minimum Circuit Ampacity 208/230V ☆			Minimum Wire Size (AWG) 208/230V‡			Min Gnd Wire Size 208/230 V	Max Fuse/Ckt Bkr Amps 208/230V			Max Wire Length 208/230V (FT)‡‡		
	230V	208V		L1, L2	L3, L4	L5, L6	L1, L2	L3, L4	L5, L6	L1, L2	L3, L4	L5, L6		L1, L2	L3, L4	L5, L6			
EHK25AHCF‡	24	18.0	1	28.9/32.0	28.9/32.0	28.9/32.0	44.7/48.5	36.2/40.0	36.2/40.0	8/8	8/8	8/8	10/10	45/50	40/40	40/40	59/60	73/73	73/73
EHK30AHCF‡	30	22.5	1	36.2/40.0	36.2/40.0	36.2/40.0	53.8/58.5	45.3/50.0	45.3/50.0	6/6	8/8	8/8	10/10	60/60	50/50	50/50	78/80	59/59	59/59

Notes:

- \* When used with Fan Coil model sizes 2400, 3600
- \*\* When used with Fan Coil model sizes 4200, 4800, 6000
- ☆ Includes blower motor amps of largest Fan Coil used with heater
- † Supplied as single phase, field convertible to 3 phase
- ‡ Supplied as 3 phase, field convertible to single phase, single or multiple supply circuits
- ‡‡ Length shown is as measured one way along wire path between unit and service panel for a voltage drop not to exceed 2%

Specifications are subject to change without notice

FAN COIL MODEL NUMBER IDENTIFICATION GUIDE								
	<b>F</b>	<b>V</b>	<b>M</b>	<b>2</b>	<b>X</b>	<b>2400</b>	<b>A</b>	<b>1</b>
F = Fan Coil								
V = Variable speed ECM motor		<b>MOTOR TYPE</b>						
M = Multiposition		<b>INSTALLATION TYPE</b>						
2 = R-22				<b>REFRIGERANT</b>				
4 = Environmentally Sound R-410A								
X = TXV				<b>METERING DEVICE</b>				
2400 = 24,000 BTUH = 2 tons								
3600 = 36,000 BTUH = 3 tons								
4800 = 48,000 BTUH = 4 tons								
6000 = 60,000 BTUH = 5 tons						<b>NOMINAL CAPACITY</b>		
Sales Code								
Engineering Revision								

ACCESSORIES PART NUMBER IDENTIFICATION GUIDE					
	<b>EB</b>	<b>AC</b>	<b>01</b>	<b>NCB</b>	<b>A</b>
EB = Evaporator Blower					
AC = Accessory					
01 = Product Identifier Number					
NCB = Non-Combustible Base Kit					
DFK = Down Flow Kit					
PLG = Power Plug (no heat kit)					
SPK = Single Point Wiring Kit					
FKS = Filter Kit Small					
FKM = Filter Kit Medium					
FKL = Filter Kit Large					
FKX = Filter Kit Extra Large					
CTK = Condensate Trap Kit (PVC pipe)					
Sales Code					

ELECTRIC HEATER MODEL NUMBER IDENTIFICATION GUIDE						
	<b>EHK</b>	<b>05</b>	<b>A</b>	<b>K</b>	<b>N</b>	<b>1</b>
EHK = Electric Heater Kit		<b>NOMINAL HEAT VALUE</b> 05 = 5 kW 07 = 7 kW 09 = 9 kW 10 = 10 kW 15 = 15 kW 18 = 18 kW 20 = 20 kW 25 = 25 kW 30 = 30 kW				
Sales Code						
K = 208 / 230 single-phase						
H = 208 / 230, 3-phase						
KC = 208 / 230, supplied as single phase, field convertible to 3-phase						
HC = 208 / 230 supplied as 3-phase, field convertible to single phase						
<b>VOLTAGE (60 Hz)</b>						
Product Identifier						
Engineering Code						