

User's Information Guide

Combination Dual Fuel Packaged Unit

IMPORTANT: Read this entire manual before proceeding and keep for future reference.

⚠ WARNING

SAFETY HAZARD!

This information is for use by individuals having adequate backgrounds of electrical and mechanical experience. Any attempt to repair a central air conditioning product may result in personal injury and/or property damage. The manufacturer or seller cannot be responsible for the interpretation of this information, nor can it assume any liability in connection with its use.

WARNING

If the information in this manual is not followed exactly, a fire or explosion may result causing property damage, personal injury or loss of life.

- Do not store or use gasoline or other flammable vapors and liquids in the vicinity of this or any other appliance.
- **WHAT TO DO IF YOU SMELL GAS**
 - Do not try to light any appliance.
 - Do not touch any electrical switch; do not use any phone in your building.
 - Immediately call your gas supplier from a neighbor's phone. Follow the gas supplier's instructions.
 - If you cannot reach your gas supplier, call the fire department.
- **DO NOT RELY ON SMELL ALONE TO DETECT LEAKS. DUE TO VARIOUS FACTORS, YOU MAY NOT BE ABLE TO SMELL FUEL GASES.**
 - U.L. recognized fuel gas and CO detectors are recommended in all applications, and their installation should be in accordance with the manufacturer's recommendations and/or local laws, rules, regulations, or customs.
- Installation and service must be performed by a qualified installer, service agency or the gas supplier.

⚠ WARNING

EXPLOSION HAZARD!

Propane gas is heavier than air and may collect in any low areas or confined spaces. In addition, odorant fade may make the gas undetectable except with a warning device. If the gas furnace is installed in a basement, an excavated area or a confined space, it is strongly recommended to contact a gas supplier to install a gas detecting warning device in case of leak. The manufacturer of your furnace does not test any detectors and makes no representations regarding any brand or type of detector.

⚠ WARNING

FIRE OR EXPLOSION HAZARD. The furnace area must be kept clear and free of combustible materials, gasoline and other flammable vapors and liquids.

Contents

General Information	1
To Start the Heating System	3
Proper Filter Maintenance	4
Regular Owner Maintenance	4
Regular Dealer Maintenance	5
Limited Warranty	6

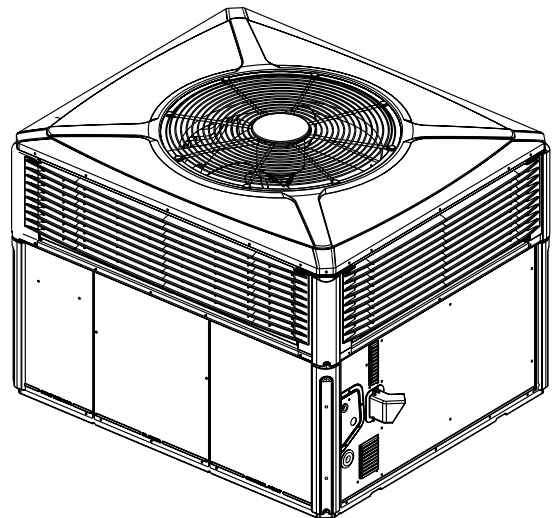

⚠ WARNING

FIRE OR EXPLOSION HAZARD. Do not use this furnace if any part has been under water. A flood-damaged furnace is extremely dangerous. Attempts to use the furnace can result in fire or explosion. A qualified service agency should be contacted to inspect the furnace and to replace all gas controls, control system parts, and electrical parts that have been wet if deemed necessary.

⚠ WARNING

FIRE OR EXPLOSION HAZARD. Should overheating occur, or the gas supply fail to shut off, shut off the manual gas valve to the furnace before shutting off the electrical supply.

In the event that electrical, fuel or mechanical failures occur, the owner should immediately turn off the gas supply at the manual gas valve located in the burner compartment and electrical power to the furnace and contact service technician.

User's Information

General Information

Understand the signal words **DANGER**, **WARNING**, and **CAUTION**. These words are safety alert words. **DANGER** indicates the most serious hazards which **will** result in severe personal injury or death. **WARNING** indicates hazards which **could** result in personal injury or death. **CAUTION** is used to indicate unsafe practices which could result in minor injury or property damage.

Overview

Your combination dual fuel heating/electric cooling unit is designed to provide comfort all year long with safe, efficient, trouble-free operation. It is important that you understand how to operate and maintain your unit to keep it operating safely and efficiently. This guide will acquaint you with these important procedures. Familiarize yourself with this manual and store it in a convenient location for future reference.

Any additions, changes, or conversions required in order for the unit to satisfactorily meet the application needs, should be made by a qualified product distributor or local dealer, using factory specified and approved parts. See Figure 1 for component layout.

Remember these instructions at all times:

- ◆ Never perform any maintenance procedures until the electrical power to the unit is turned off.
- ◆ Never perform any maintenance procedures until the gas valve in the gas supply line is turned off.
- ◆ Never remove any panel from the unit while it is operating.
- ◆ Never remove panels or parts from the unit that are not discussed in this guide.
- ◆ Never cover the unit since it is designed to operate year round.
- ◆ Never store anything flammable or combustible around or near the unit.

Your unit is of complex design. To ensure that it performs safely and gives long-lasting service, some of the maintenance work must be performed by a qualified service technician.

When a service technician is referred to in this manual, it is describing a **service technician that has had special training or a number of years experience in servicing this type of equipment**. It is your responsibility to select a qualified service company that can provide a service technician of this caliber.

Thermostat

Room thermostats are delicate temperature-sensing controls. Their main function is to energize and de-energize the heating or cooling circuit to maintain the temperature setting you select.

Many thermostats contain a room thermometer to indicate the approximate room temperature, and a temperature scale to select the desired indoor air temperature. In addition, most thermostats have modes of HEAT, OFF and COOL, and fan modes of ON and AUTO.

When OFF is selected your unit will not operate in either heat or cool modes. If HEAT or COOL is selected, the unit will automatically cycle on and off to maintain the desired temperature settings.

When AUTO is selected, the fan will only operate as required during the heating or cooling cycles. The fan mode can be used to operate the indoor fan continuously by selecting ON.

Continuous fan mode during cooling operation may not be appropriate in humid climates. If the indoor air exceeds 60% relative humidity or simply feels uncomfortably humid, it is recommended that the fan only be used in the AUTO mode.

To ensure that the thermostat operates properly, it must be level and positioned to avoid the influence of such external heat sources as lamps, televisions or other heat-producing appliances.

Two Stage Cooling Models --For units with the feature of two staged cooling, the thermostat will determine whether to run the system at the full capacity or a lower capacity. This depends on the daily cooling load of the conditioned space. The system is more efficient when running at low capacity (1st stage). At lower outdoor temperatures 1st stage will be sufficient to maintain indoor comfort.

With the thermostat set to COOL, the system will automatically cycle on and off as well as from low (1st stage) to high (2nd stage) as needed to maintain the thermostat set point for indoor comfort. During 1st stage operation the compressor, as well as the indoor fan, will run at a reduced speed. This produces a reduced capacity which is more efficient than the high capacity 2nd stage. If the low capacity (1st stage) is not sufficient to maintain the thermostat setting, the system will switch to high speed (2nd stage). As the thermostat temperature setting is reached, the system will cycle to low speed then off.

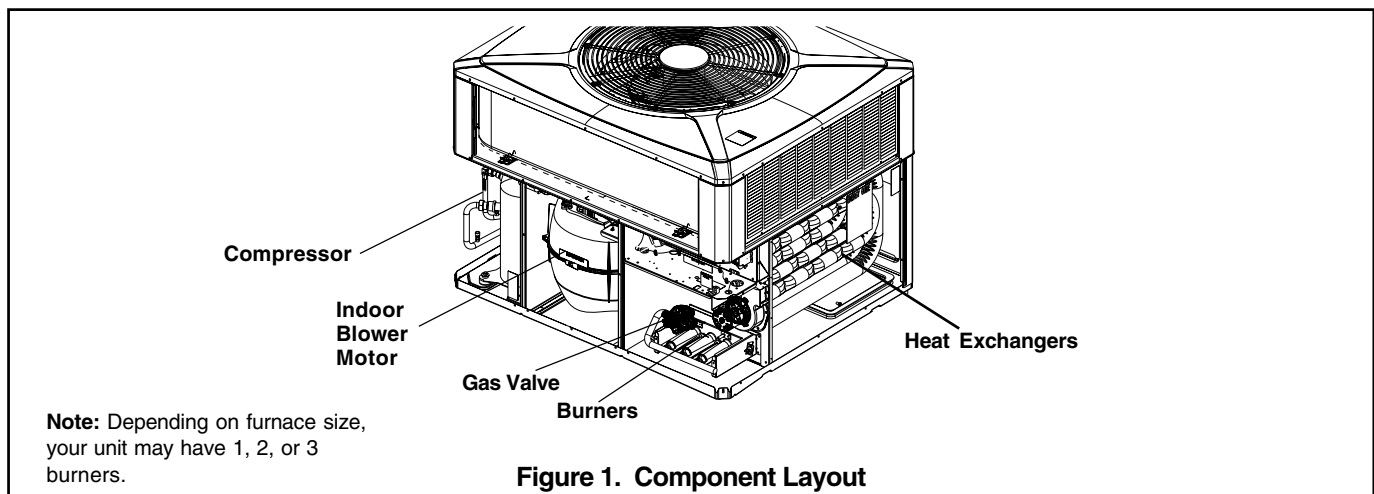

User's Information

To Start the Heating System

Heating Cycle Operation

Your unit's gas heating system has a solid-state electronic ignition control that lights the furnace burners each time the thermostat calls for gas heat. At the end of each gas heating cycle, the furnace burners are extinguished. This type of system is called Direct Spark Ignition (DSI).

A normal gas heating cycle begins when the air temperature in your home drops below the thermostat setting. The thermostat then energizes the heating electrical circuit that starts and controls the furnace burners. Shortly after the burners ignite, the indoor fan starts and circulates warm air through your home.

When the air temperature rises above the thermostat setting, the thermostat de-energizes the heating electrical circuit, which in turn, extinguishes the furnace burners. The indoor fan continues to circulate warm air until the remaining heat is removed from the unit's heat exchanger.

Safety Controls

Your unit is equipped with an automatic reset safety limit control to prevent overheating. When this control opens, it shuts down the heating electrical circuit until the unit cools down sufficiently. Inadequate airflow may cause the unit to cycle on and off as the limit control trips and automatically resets. If you suspect that the unit is cycling on its limit control, immediately contact a service technician for instructions.

If the unit is unable to exhaust combustion by-products properly, due to a blocked flue hood or other blockage, a pressure switch safety device will prohibit the unit from operating. The cause must be investigated by a qualified service technician.

If flames from the burner are not properly drawn into the heat exchanger, a Flame Rollout Protection Control will open causing the furnace to shut off. The cause must be investigated by a qualified service technician.

Heating System Start Up

CAUTION

Never attempt to manually light the burner. This unit is equipped with an ignition device which automatically lights the burners.

Your unit has an automatic ignition system. This feature makes it easy to start the heating cycle at the beginning of the heating season.

In order for this unit to operate properly and safely, the furnace needs air for both combustion and ventilation. Accordingly, observe the area in which the furnace is installed. Check to make sure that all the air openings are unobstructed. Likewise, insure that the spacing around the furnace itself is not blocked or obstructed.

1. Set the thermostat to lowest setting.
2. Turn off all electric power to the unit if service is to be performed.

3. Remove the access panel that is identified as CONTROL/HEAT.
4. Turn gas control **off** by moving the toggle switch to OFF. See Figure 2 on page 5.
5. Wait five (5) minutes to clear any gas. If you then smell gas, STOP!, for your safety follow the "What To Do If You Smell Gas" instructions on the front page. If you do not smell gas, go to next step.
6. Turn gas **on** by moving the toggle switch to ON.
7. Replace the panel that you removed in Step 3 and make sure all other unit panels are securely in place.
8. Turn on all electrical power to the unit.
9. Set thermostat to desired temperature and the fan to ON. The unit will now operate automatically.
10. If the unit will not operate, perform the steps in the following section, "To Turn Off Gas To Unit" (under Heating System Shutdown) and call your service technician or gas supplier.

NOTE: The unit is to be adjusted to obtain a temp air rise that is specified on the nameplate.

Heating System Shutdown

To shut down the heating system for brief periods of time, simply adjust the thermostat selector switch to the OFF position.

If you need to turn the gas off to the unit, follow the steps below:

To Turn Off Gas To Unit

1. Set the thermostat to lowest setting.
2. Turn off all electric power to the unit if service is to be performed.
3. Remove the access panel that is identified as CONTROL/HEAT.
4. Turn gas control **off** by moving the toggle switch to OFF. See Figure 2 on page 5.
5. Replace the panel you removed in Step 3.

CAUTION

If you shutdown your heating system during the cold weather months, precautions must be taken to prevent freeze-up of all water pipes and water receptacles. Whenever your home or building is to be vacant, arrange to have someone inspect your structure for proper temperature. This is very important in below freezing weather. If for any reason your furnace should fail to operate, damage such as frozen water pipes could result.

User's Information

To Start the Cooling System

Cooling Cycle Operation

Cooling System Start Up

Once electrical power is supplied to the unit, cooling operation is controlled by the comfort control. With the mode set at COOL, adjust the comfort control to the desired room temperature. Your unit will continue to operate in the cooling mode automatically.

Cooling System Shutdown

If you wish to shut down the cooling system, the best method is to select the OFF mode.

To shut down the unit completely, turn off the main electrical power supply to the unit.

Anytime you suspect that the cooling system is not operating properly, shut down unit operation at the comfort control and contact your qualified service technician for instructions.

Proper Filter Maintenance

Air Filters

Use air filters with the dual fuel heating/cooling units. The basic unit does not ship with filters in it, however, a filter accessory is offered that will allow filters to be installed in the unit. Otherwise a filter rack must be installed in the duct work by a qualified installer. Affix filter label supplied with the unit adjacent to the filter area.

Filters must be installed in the return air system. The data in Table 1 is based on 300 FPM face velocity. If permanent filters are used, be sure to size following the manufacturer's recommendations with a clean filter resistance of 0.08 inches of water column.

Table 1 -- Filter Data

UNIT	NOMINAL CFM	FILTER SIZE sq. ft.	FILTER RESISTANCE
4DC**024A	800	2.67	0.08
4DC**036A	1200	4.00	0.08
4DC**048A	1600	5.33	0.08
4DC**060A	2000	6.67	0.08

Regular Owner Maintenance

⚠ CAUTION

Never use combustible cleaning fluids on any part of the furnace.

You can perform some of the periodic maintenance functions for the unit yourself; this includes replacing (disposable) or cleaning (permanent) the air filters, cleaning the cabinet, cleaning the condenser coil, and conducting a general unit inspection on a regular basis.

Air Filters

It is very important to keep the central duct system air filters clean. Be sure to inspect them at least once each month when the system is in constant operation (in new homes, check the filters weekly for the first 4 weeks).

If you have a disposable-type filter replace it with a new filter of the same type and size. **DO NOT ATTEMPT TO CLEAN DISPOSABLE FILTERS.**

Permanent-type filters can be cleaned by washing them with a mild detergent and water. Make sure that the filters are thoroughly dry before reinstalling them in the unit (or duct system).

Note: It may be necessary to replace permanent filters annually if washing fails to clean the filter, or if the filter shows signs of deterioration. Be sure to use the same type and size as was originally installed.

Unit Cabinet

Even though the unit cabinet is designed to withstand exposure to outdoor weather, you can extend the life of the cabinet panel by cleaning and waxing it twice each year. Application of a light coat of automobile wax is recommended.

Condenser Coil

Unfiltered air circulates through the units condenser coil and can cause the coil's surface to become clogged with dust and dirt. Have the coils checked by a service technician each cooling season.

Be sure to keep all vegetation away from the condenser coil area.

General Unit Inspection

Occasionally check over the unit; look and listen for unusual or abnormal operating characteristics. Do not remove any access panels. If you suspect your unit is not operating properly, contact a service technician for instructions.

Regular Service Maintenance

⚠ WARNING

ELECTRIC SHOCK HAZARD. To prevent injury or death due to electrical shock or contact with moving parts. Lock unit disconnect switch in open position before servicing unit.

Cooling Season

To keep your unit operating safely and efficiently, a qualified service technician should check the entire system seasonally, and any other time that you feel a check is needed. Your service technician may examine these areas of the unit:

1. **filters** (for possible cleaning)
2. **motors** (condenser and evaporator motors are permanently lubricated)
3. **gaskets** (for possible replacement)
4. **refrigerant coils** (for possible cleaning)
5. **safety controls** (for mechanical cleaning)
6. **electrical components and wiring** (for possible replacement and connection tightness)
7. **condensate drain** (for possible cleaning)
8. inspect the unit duct connections to see that they are physically sound and sealed to the unit casing.
9. inspect the unit mounting support to see that it is sound.
10. inspect the unit to see that there is no obvious unit deterioration.

Heating Season

At the beginning of each heating season complete the unit inspections and service routines described in this section.

These steps should be performed **ONLY** by a qualified service technician.

1. Inspect the control panel wiring and heating controls to make sure connections are tight and wiring insulation is intact.
2. Check the operation of the gas ignition system.
 - a. Turn the unit on and off at the thermostat to be sure the ignition control and spark electrode are operating.
 - b. Turn off the gas supply with the unit operating to verify that the gas valve closes and that a re-ignition cycle is initiated by the ignition control.
3. Check the burner manifold pressure. A pressure tap is provided in the gas valve for this purpose.

⚠ WARNING

HAZARDOUS GASSES!

Exposure to fuel substances, or by-products of incomplete fuel combustion, is believed by the state of California to cause cancer, birth defects, or other reproductive harm. This warning complies with State of California law, Proposition 65.

This product must be gas piped by a Licensed Plumber or Gas Fitter in the Commonwealth of Massachusetts.

4. Visually inspect all of the unit's flue product passageways for excessive deposit buildup or corrosion. If buildup or corrosion is apparent, perform the necessary repairs.
5. Arrange for a qualified service technician to inspect the unit every heating season to maintain safe and efficient operation.
6. Visually check the main burner flames. They should be bright blue flames extending up to the heat exchanger sections.

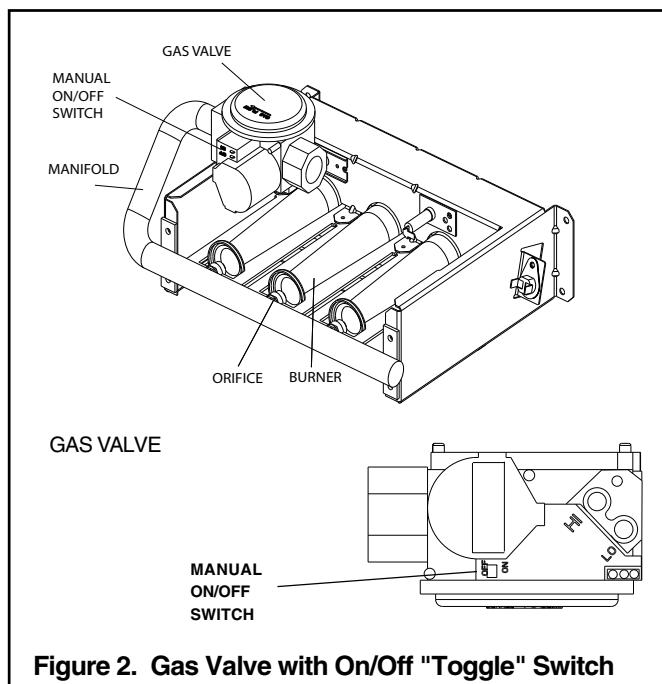

Figure 2. Gas Valve with On/Off "Toggle" Switch

⚠ WARNING

ELECTRIC SHOCK HAZARD. Should overheating occur, or the gas supply fail to shut off, shut off the manual gas valve to the furnace before shutting off the electrical supply.

In the event that electrical, fuel or mechanical failures occur, the owner should immediately turn off the gas supply at the manual gas valve located in the burner compartment and electrical power to the furnace and contact service technician.

IMPORTANT: This product has been designed and manufactured to meet ENERGY STAR criteria for energy efficiency. However, proper refrigerant charge and proper air flow are critical to achieve rated capacity and efficiency. Installation of this product should follow the manufacturer's refrigerant charging and air flow instructions. **Failure to confirm proper charge and airflow may reduce energy efficiency and shorten equipment life.**



Limited Warranty Combination Heat Pump / Gas Electric 4DCZ6 and 4DCY4 (Parts Only)

Models Less Than 20 Tons for Residential Use*

This limited warranty is extended by the manufacturer to the original purchaser and to any succeeding owner of the real property to which the combination Heat Pump/Gas Electric unit is originally affixed, and applies to products purchased and retained for use within the U.S.A. and Canada.

Beginning on January 1, 2010, R-22 refrigerant will no longer be used as a manufacturer-installed refrigerant as required by federal regulation. Following this date, depending on the availability of any remaining R-22 equipment, packaged unit model replacements may require that the entire system be R-410A compatible. Packaged units and possibly connecting line sets would need to be replaced in order to be compatible with R-410A refrigerant. Expenses associated with replacing system components that are not R-410A compatible will not be covered by the terms and conditions of the limited warranty.

The limited warranty period begins when installation is complete and the packaged unit start-up procedure has been properly completed, verified by installer's invoice or similar document. If installation completion and start-up date cannot be verified by installer's invoice or similar document, limited warranty coverage begins six (6) months after the date of manufacture based on the packaged unit serial number.

If any part of your Combination Heat Pump/Gas Electric fails because of a manufacturing defect within five years from the date the limited warranty period begins, Warrantor will furnish without charge the required replacement part. Any local transportation, related service labor, diagnosis calls, air filters, refrigerant and related items are not included.

In addition, if the sealed motor-compressor(s) fail(s) or the outdoor coil† should become defective, either or both events occurring because of a manufacturing defect within the sixth through tenth year from the date the limited warranty period begins, Warrantor will furnish without charge the required replacement compressor and/or outdoor coil. Any local transportation, related service labor, diagnosis calls, refrigerant and related items are not included.

† NOTE: If your Combination Heat Pump/Gas Electric is installed within one mile of salt water, including but not limited to seacoasts and inland waterways, your outdoor coil warranty as stated above is limited to five years from the date the limited warranty period begins.

In addition, if the heat exchanger fails because of a manufacturing defect within the sixth through twentieth year from the date the limited warranty period begins, Warrantor will furnish without charge a replacement heat exchanger.

Any local transportation, related service labor and diagnosis calls are not included.

This limited warranty does not apply if the packaged unit was purchased direct (i.e. from internet websites or auctions) on an uninstalled basis. Additionally, this limited warranty will not apply unless the packaged unit is: (1) installed by a licensed or qualified HVAC technician, (2) applied and installed in accordance with the manufacturer's recommendations and its Installer's guide and (3) in compliance with all industry standards, national, state and local codes.

This limited warranty does not cover failure of your packaged unit if it is damaged while in your possession; including, but not limited to (1) damage caused by unreasonable use, (2) damage from failure to properly maintain as set forth in the Use and Care manual or Installer's Guide (refer to "Proper Maintenance" section), (3) damage that is not considered a manufacturing defect, such as acts of God, malfunctions or failures resulting from fire, water, storms, lightning, earthquake, faulty power supply or power surges, corrosive environments, insect or vermin infestation, theft, riot, misuse, abuse, increased utility usage costs, or (4) performance problems due to improper selection / equipment matchup, installation or application.

THE LIMITED WARRANTY AND LIABILITY SET FORTH HEREIN ARE IN LIEU OF ALL OTHER WARRANTIES AND LIABILITIES, WHETHER IN CONTRACT OR IN NEGLIGENCE, EXPRESS OR IMPLIED, IN LAW OR IN FACT, INCLUDING IMPLIED WARRANTIES OF MERCHANTABILITY AND FITNESS FOR PARTICULAR USE, AND IN NO EVENT SHALL WARRANTOR BE LIABLE FOR ANY INCIDENTAL OR CONSEQUENTIAL DAMAGES.

Some states do not allow limitations on how long an implied limited warranty lasts or do not allow the exclusion or limitation of incidental or consequential damages, so the above limitation or exclusion may not apply to you.

This limited warranty gives you specific legal rights, and you may also have other rights which vary from state to state.

Parts will be provided by our factory organization through an authorized service organization in your area listed in the yellow pages. If you wish further help or information concerning this limited warranty, contact:

Residential Systems
6200 Troup Highway, Tyler, TX 75707
Attention: Consumer Relations

Or visit our website: www.trane.com/residential Or visit our website: www.americanstandair.com

TW-1006-3308

* This limited warranty is for residential use of this equipment and is not applicable when this equipment is used for a commercial application. A commercial use is any application where the end purchaser uses the product for other than personal, family or household purposes.

The limited warranties displayed in this publication and/or on ComfortSite™ may not accurately reflect the actual limited warranty that shipped with the product.

26-1000-22



Limited Warranty Combination Heat Pump / Gas Electric 4DCZ6 and 4DCY4 (Parts Only)

Models Less Than 20 Tons for Commercial Use*

This limited warranty is extended by the manufacturer to the original purchaser and to any succeeding owner of the real property to which the combination Heat Pump/Gas Electric unit is originally affixed, and applies to products purchased and retained for use within the U.S.A. and Canada. There is no warranty against corrosion, erosion or deterioration.

Beginning on January 1, 2010, R-22 refrigerant will no longer be used as a manufacturer-installed refrigerant as required by federal regulation. Following this date, depending on the availability of any remaining R-22 equipment, packaged unit model replacements may require that the entire system be R-410A compatible. Packaged units and possibly connecting line sets would need to be replaced in order to be compatible with R-410A refrigerant. Expenses associated with replacing system components that are not R-410A compatible will not be covered by the terms and conditions of the limited warranty.

The limited warranty period begins when installation is complete and the packaged unit start-up procedure has been properly completed, verified by installer's invoice or similar document. If installation completion and start-up date cannot be verified by installer's invoice or similar document, limited warranty coverage begins six (6) months after the date of manufacture based on the packaged unit serial number.

If any part of your Combination Heat Pump/Gas Electric fails because of a manufacturing defect within one year from the date the limited warranty period begins, Warrantor will furnish without charge the required replacement part. In addition, if the sealed motor-compressor fails because of a manufacturing defect within the second through fifth year from the date the limited warranty period begins, Warrantor will furnish without charge the required replacement compressor. Warrantor's obligations and liabilities under this warranty are limited to furnishing F.O.B. Warrantor factory or warehouse replacement parts for Warrantor's products covered under this warranty. Warrantor shall not be obligated to pay for the cost of lost refrigerant. No liability shall attach to Warrantor until products have been paid for and then liability shall be limited solely to the purchase price of the equipment under warranty shown to be defective.

In addition, if the heat exchanger fails because of a manufacturing defect within the second through fifth year from the date the limited warranty period begins, Warrantor will furnish without charge a replacement heat exchanger.

This limited warranty does not apply if the packaged unit was purchased direct (i.e. from internet websites or auctions) on an uninstalled basis. Additionally, this limited warranty will not apply unless the packaged unit is: (1) installed by a licensed or qualified HVAC technician, (2) applied and installed in accordance with the manufacturer's recommendations and its Installer's guide and (3) in compliance with all industry standards, national, state and local codes.

This limited warranty does not cover failure of your packaged unit if it is damaged while in your possession; including, but not limited to (1) damage caused by unreasonable use, (2) damage from failure to properly maintain as set forth in the Use and Care manual or Installer's Guide (refer to "Proper Maintenance" section), (3) damage that is not considered a manufacturing defect, such as acts of God, malfunctions or failures resulting from fire, water, storms, lightning, earthquake, faulty power supply or power surges, corrosive environments, insect or vermin infestation, theft, riot, misuse, abuse, increased utility usage costs, or (4) performance problems due to improper selection / equipment matchup, installation or application.

THE WARRANTY AND LIABILITY SET FORTH HEREIN ARE IN LIEU OF ALL OTHER WARRANTIES AND LIABILITIES, WHETHER IN CONTRACT OR IN NEGLIGENCE, EXPRESS OR IMPLIED, IN LAW OR IN FACT, INCLUDING IMPLIED WARRANTIES OF MERCHANTABILITY AND FITNESS FOR PARTICULAR USE, AND IN NO EVENT SHALL WARRANTOR BE LIABLE FOR ANY INCIDENTAL OR CONSEQUENTIAL DAMAGES.

Some states do not allow limitations on how long an implied warranty lasts or do not allow the exclusion or limitation of incidental or consequential damages, so the above limitation or exclusion may not apply to you.

This warranty gives you specific legal rights, and you may also have other rights which vary from state to state.

Residential Systems
6200 Troup Highway, Tyler, TX 75707
Attention: Consumer Relations

Or visit our website: www.trane.com/residential

TW-1007-3308

* This warranty is for commercial usage of said equipment and not applicable when the equipment is used for a residential application. Commercial use is any application where the end purchaser uses the product for other than personal, family or household purposes.

