

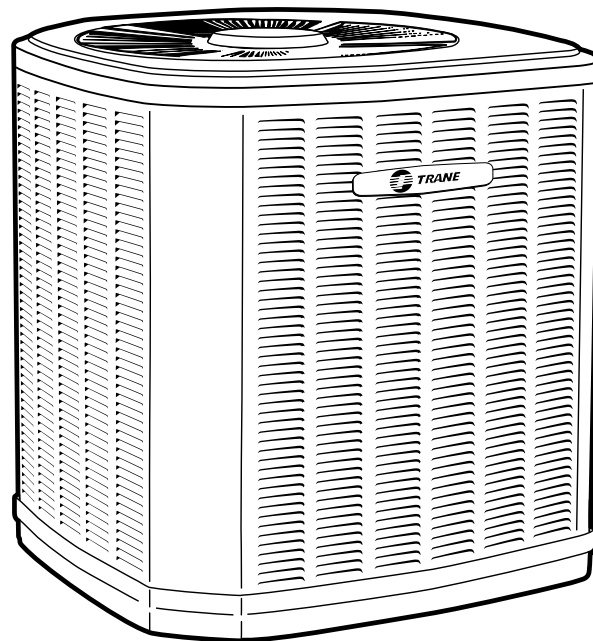

Split System Heat Pump Product & Performance Data

XR 13
4TWR3018-060

1½ – 5 Tons





Features and Benefits

- **Climatuff**® compressor
- All aluminum **Spine Fin**™ coil
- **Quick-Sess**™ cabinet, service access and refrigerant connections with full coil protection
- **DuraTuff**™ base, fast complete drain, weather proof
- Glossy corrosion resistant finish
- Internal compressor high/low pressure and temperature protection
- 018, 024, 030 and 060 ship with Start Kit
- Liquid line filter-drier
- Polyslate gray cabinet
- Low Pressure Switch
- Demand Defrost Control
- High Pressure Switch
- R-410A refrigerant
- **10 year limited warranty on compressor, coil and 5 years on parts (Residential Use)**
- **Extended warranties available**
- 100% line run test
- Low ambient cooling to 55°F as shipped
- Low ambient cooling to 30°F with EDC accessory AY28X084 and TXV

Contents

Features and Benefits	2
General Data	4
Product Specifications	4
A-weighted Sound Power Level [dB(A)]	4
Accessory Description and Usage	5
ARI Standard Capacity Rating Conditions	5
Model Nomenclature	6
Electrical Data	7
Dimensions	10
Mechanical Specification Options	11



General Data

Product Specifications

Model No. ①	4TWR3018A1	4TWR3024A1	4TWR3030A1	4TWR3036A1
Electrical Data V/Ph/Hz ②	200/230/1/60	200/230/1/60	200/230/1/60	208/230/1/60
Min Cir Ampacity	10	12	15	21
Max Fuse Size (Amps)	15	20	25	35
Compressor	CLIMATUFF®	CLIMATUFF®	CLIMATUFF®	CLIMATUFF® - SCROLL
RL Amps - LR Amps	7.7 - 38.6	9.4 - 63	11.7 - 68.2	15.4 - 83
Outdoor Fan FL Amps	0.7	0.7	0.7	1.3
Fan HP	1/8	1/8	1/8	1/4
Fan Dia (inches)	23.0	23.0	23.0	27.6
Coil	Spine Fin™	Spine Fin™	Spine Fin™	Spine Fin™
Refrigerant R-410A	5/12-LB/OZ	5/12-LB/OZ	6/01-LB/OZ	7/15-LB/OZ
Line Size - (in.) O.D. Gas ③	1/2	5/8	3/4	3/4
Line Size - (in.) O.D. Liquid ③	1/4	5/16	5/16	3/8
Charge Spec. Subcooling	10°	11°	11°	10°
Dimensions H x W x D (Crated)	34 x 30.1 x 33	34 x 30.1 x 33	42 x 30.1 x 33	42.4 x 35.1 x 38.7
Weight - Shipping	221	225	238	280
Weight - Net	194	197	210	245
Start Components	YES	YES	YES	NO
Sound Enclosure	YES	YES	YES	NO
Compressor Sump Heat	NO	YES	YES	YES
Optional Accessories: ④				
Anti-short Cycle Timer	TAYASCT501A	TAYASCT501A	TAYASCT501A	TAYASCT501A
Evaporator Defrost Control	AY28X084	AY28X084	AY28X084	AY28X084
Rubber Isolator Kit	BAYISLT101	BAYISLT101	BAYISLT101	BAYISLT101
Snow Leg-Base & Cap 4" High	BAYLEGS002	BAYLEGS002	BAYLEGS002	BAYLEGS002
Snow Leg-4" Extension	BAYLEGS003	BAYLEGS003	BAYLEGS003	BAYLEGS003
Extreme Condition Mounting Kit	BAYECMT023	BAYECMT023	BAYECMT023	BAYECMT004
Start Kit				BAYSKT260
Crankcase Heater Kit	BAYCCHT300			
Seacoast Kit	BAYSEAC001	BAYSEAC001	BAYSEAC001	BAYSEAC001
Low Ambient Kit	BAYLOAM103	BAYLOAM103	BAYLOAM103	BAYLOAM103
Refrigerant Lineset ⑤	TAYREFLN5*	TAYREFLN6*	TAYREFLN2*	TAYREFLN7*

① Certified in accordance with the Air-Source Unitary Heat Pump equipment certification program which is based on ARI Standard 210/240.

② Calculated in accordance with N.E.C. Only use HACR circuit breakers or fuses.

③ Standard line lengths - 60'. Standard lift - 60' Suction and Liquid line.

For Greater lengths and lifts refer to refrigerant piping software Pub# 32-3312-01. (*denotes latest revision)

④ For accessory description and usage, see page 5.

⑤ * = 15, 20, 25, 30, 40 and 50 foot lineset available.

A-weighted Sound Power Level [dB(A)]

MODEL	SOUND POWER LEVEL [dB(A)]	A-WEIGHTED FULL OCTAVE SOUND POWER LEVEL dB - [dB(A)]							
		63	125	250	500	1000	2000	4000	8000
4TWR3018A1	76	47.7	61.8	66.1	71.2	70.7	68.2	57.7	49.4
4TWR3024A1	76	45.5	59.9	66.2	70.1	70.6	69.2	61.7	59.6
4TWR3030A1	76	45.3	58.7	65.1	69.3	69.3	66.7	57.9	53.3
4TWR3036A1	75	47.5	57.2	59.1	66.8	68.2	62.9	56.7	52.9
4TWR3042A1	75	48.2	56.2	60.4	66.6	69.3	63.7	57.2	49.3
4TWR3048A1	76	46.3	56.5	66.3	72.9	72.6	68.7	60.3	48.3
4TWR3060A1	76	54.7	54.7	59.9	67.2	70.7	66.7	61.4	52.8

Note: Tested in accordance with ARI Standard 270.95. (Not listed with ARI)



General Data

Product Specifications

Model No. ①	4TWR3042A1	4TWR3048A1	4TWR3060A1
Electrical Data V/Ph/Hz ②	208/230/1/60	208/230/1/60	208/230/1/60
Min Cir Ampacity	25	30	36
Max Fuse Size (Amps)	40	50	60
Compressor	CLIMATUFF® - SCROLL	CLIMATUFF® - SCROLL	CLIMATUFF® - SCROLL
RL Amps - LR Amps	18.6 - 105	23.1 - 134	27.6 - 158
Outdoor Fan FL Amps	1.3	1.3	1.3
Fan HP	1/4	1/4	1/4
Fan Dia (inches)	27.6	27.6	27.6
Coil	Spine Fin™	Spine Fin™	Spine Fin™
Refrigerant R-410A	8/03-LB/OZ	8/10-LB/OZ	9/07-LB/OZ
Line Size - (in.) O.D. Gas ③	3/4	7/8	7/8
Line Size - (in.) O.D. Liquid ③	3/8	3/8	3/8
Charge Spec. Subcooling	10°	10°	13°
Dimensions H x W x D (Crated)	42.4 x 35.1 x 38.7	46.4 x 35.1 x 38.7	46.4 x 35.1 x 38.7
Weight - Shipping	281	294	317
Weight - Net	246	259	282
Start Components	NO	NO	YES
Sound Enclosure	NO	NO	NO
Compressor Sump Heat	YES	YES	YES
Optional Accessories: ④			
Anti-short Cycle Timer	TAYASCT501A	TAYASCT501A	TAYASCT501A
Evaporator Defrost Control	AY28X084	AY28X084	AY28X084
Rubber Isolator Kit	BAYISLT101	BAYISLT101	BAYISLT101
Snow Leg-Base & Cap 4" High	BAYLEGS002	BAYLEGS002	BAYLEGS002
Snow Leg-4" Extension	BAYLEGS003	BAYLEGS003	BAYLEGS003
Extreme Condition Mounting Kit	BAYECMT004	BAYECMT004	BAYECMT004
Start Kit	BAYKSKT260	BAYKSKT260	
Crankcase Heater Kit			
Seacoast Kit	BAYSEAC001	BAYSEAC001	BAYSEAC001
Low Ambient Kit	BAYLOAM103	BAYLOAM103	BAYLOAM103
Refrigerant Lineset ⑤	TAYREFLN7*	TAYREFLN3*	TAYREFLN3*

Accessory Description and Usage

Anti-Short Cycle Timer — Solid state timing device that prevents compressor recycling until five (5) minutes have elapsed after satisfying call or power interruptions. Use in area with questionable power delivery, commercial applications, long lineset, etc.

Evaporator Defrost Control — SPST Temperature actuated switch that cycles the condenser off as indoor coil reaches freeze-up conditions. Used for low ambient cooling to 30°F with TXV.

Rubber Isolators — Five (5) large rubber donuts to isolate condensing unit from transmitting energy into mounting frame or pad. Use on any application where sound transmission needs to be minimized.

Hard Start kit — Start capacitor and relay to assist compressor motor startup. Use in areas with marginal power supply, on long linesets, low ambient conditions, etc.

Extreme Condition Mount Kit — Bracket kits to securely mount condensing unit to a frame or pad without removing any panels. Use in areas with high winds, or on commercial roof tops, etc.

ARI Standard Capacity Rating Conditions

ARI STANDARD 210/240 RATING CONDITIONS —

- (A) Cooling 80°F DB, 67°F WB air entering indoor coil, 95°F DB air entering outdoor coil.
- (B) High Temperature Heating 47°F DB, 43°F WB air entering outdoor coil, 70°F DB air entering indoor coil.
- (C) Low Temperature Heating 17°F DB, 15°F WB air entering outdoor coil, 70°F DB air entering indoor coil.
- (D) Rated indoor airflow for heating is the same as for cooling.

ARI STANDARD 270 RATING CONDITIONS — (Noise rating numbers are determined with the unit in cooling operation.)

Standard Noise Rating number is at 95°F outdoor air.



ARI Standard
210/240 UHP





Model Nomenclature

Outdoor Units

4 T W R 3 0 3 6 A 1 0 0 0 A

- Refrigerant Type**
 - 2 = R-22
 - 4 = R-410A
- TRANE**
- Product Type**
 - W = Split Heat Pump
 - T = Split Cooling
- Product Family**
 - Z = Leadership – Two Stage
 - X = Leadership
 - R = Replacement/Retail
 - B = Basic
 - A = Light Commercial
- Family SEER**
 - 0 = 10 3 = 13 6 = 16
 - 1 = 11 4 = 14 8 = 18
 - 2 = 12 5 = 15 9 = 19
- Split System Connections 1-6 Tons**
 - 0 = Brazed
- Nominal Capacity in 000s of BTUs**
- Major Design Modifications**
- Power Supply**
 - 1 = 200-230/1/60 or 208-230/1/60
 - 3 = 200-230/3/60
 - 4 = 460/3/60
- Secondary Function**
- Minor Design Modifications**
- Unit Parts Identifier**

High Efficiency Furnaces

T U D 1 B 0 8 0 A 9 H 3 1 A A

- Furnace Configuration**
 - TU = Upflow / Horizontal
 - TD = Downflow / Horizontal
- Type**
 - D = 80% Premium
 - X = 90% Premium
- Number of Heating Stages**
 - 1 = Single Stage
 - 2 = Two Stage
 - 3 = Three Stage
- Cabinet Width**
 - A = 14.5" Cabinet Width
 - B = 17.5" Cabinet Width
 - C = 21.0" Cabinet Width
 - D = 24.5" Cabinet Width
- Heating Input**
 - 080 = 80,000 BTUH
- Major Design Change**
- Power Supply / Fuel**
 - 9 = 115 Volts / Natural Gas
 - F = 115 Volts / Natural Gas with Integrated iFD Filter
- Airflow Capacity for Cooling**
 - 36 = 3 Ton Standard PSC Motor
 - H3 = 3 Ton High Efficiency Motor
 - V3 = 3 Ton Variable Speed Motor
- Draft Inducer Speeds**
 - 1 = Single Speed
 - 2 = Two Speed
 - V = Variable Speed
- Minor Design Change**
- Service Digit** – Not Orderable

Air Handlers – Residential

4 T E E 3 F 3 6 A 1 0 0 0 A

- Refrigerant Type**
 - 4 = R-410A
 - 2 = R-22
- Application**
 - TE = Fully Convertible
 - TG = Semi Convertible
 - TF = Front Return
 - TV = Vertical
- Product Family**
 - E = Leadership – Variable Speed
 - P = Leadership
 - C = Replacement/Retail
 - B = Basic
- Flow Control**
 - 3 = Nonbleed TXV
 - 4 = FCCV*
- Feature Identifier**
 - 0 = Standard Unit
 - F = Air-Tite™
- Nominal Capacity in 000s of BTUs**
- Major Design Modifications**
- Power Supply**
 - 1 = Single Phase
- Electrical Connection**
 - 0 = Pig Tails
 - B = Circuit Breaker
 - D = Pull Disconnect
- Future Option – Factory Installed Heater Nominal KW Value**
- Minor Design Modifications**
- Unit Parts Identifier**

Heat Pump / Cooling Coils

2 T X C B 0 3 6 A C 3 H C A A

- Refrigerant Type**
 - 2 = R-22 4 = R-410A
- Product Family**
 - T = Premium (Heat Pump or Convertible Coil)
 - C = Standard (Cooling Only)
- Coil Design**
 - X = Direct Expansion Evaporator Coil
- Product Family**
 - C = Cased A Coil
 - A = Uncased A Coil
 - F = Cased Horizontal Flat Coil
- Coil Width (Cased / Uncased)**
 - A = 14.5" / 13.3" C = 21.0" / 19.8" H = 10.5"
 - B = 17.5" / 16.3" D = 24.5" / 23.3"
- Refrigerant Line Coupling**
 - 0 = Brazed
- Nominal Capacity in 000s of BTUs**
- Major Design Change**
- Efficiency**
 - C = Standard S = Hi Efficiency
- Refrigerant Control**
 - 3 = TXV – Non-Bleed
- Coil Circuitry**
 - H = Heat Pump
 - C = Cooling Only
- Airflow Configuration**
 - A = Upflow Only
 - U = Upflow / Downflow
 - H = Horizontal Only
 - C = Convertible – Upflow, Downflow, Left Airflow
 - M = Convertible – Upflow, Downflow, Left or Right Airflow
- Minor Design Change**
- Unit Parts Identifier**

NOTE: There will be a phase-in of new model numbers for new air handlers over next 2 years.
*Shipped with R-22 FCCV



Electrical Data

SCHEMATIC DIAGRAMS

4TWR3036,042A

4TWR3048A

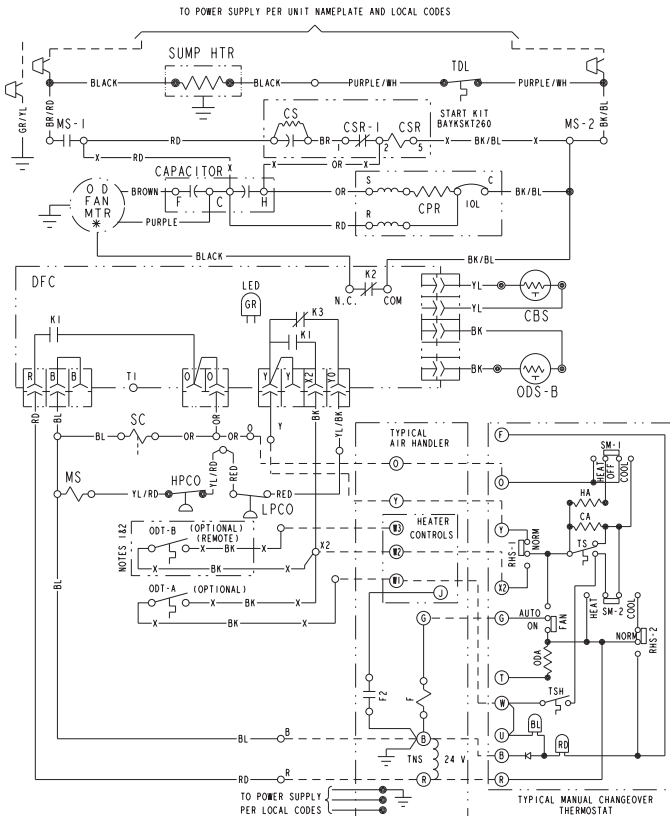

NOTES:

1. IF ODT-B IS NOT USED, ADD JUMPER BETWEEN W2 & W3 AT AIR HANDLER.
IF USED, ODT-B MUST BE MOUNTED REMOTE OF CONTROL BOX IN AN APPROVED WEATHER PROOF ENCLOSURE.
2. IF ODT-A IS NOT USED, ADD JUMPER BETWEEN W1 & W2 AT AIR HANDLER.
3. LOW VOLTAGE (24 V.) FIELD WIRING MUST BE 18 AWG MIN.

<p>⚠ WARNING HAZARDOUS VOLTAGE! DISCONNECT ALL ELECTRIC POWER INCLUDING REMOTE DISCONNECTS BEFORE SERVICING. FAILURE TO DISCONNECT POWER BEFORE SERVICING CAN CAUSE SEVERE PERSONAL INJURY OR DEATH!</p>	<p>⚠ CAUTION USE COPPER CONDUCTORS ONLY! UNIT TERMINALS ARE NOT DESIGNED TO ACCEPT OTHER TYPES OF CONDUCTORS. FAILURE TO DO SO MAY CAUSE DAMAGE TO THE EQUIPMENT!</p>
-----------------------------------------------------------------------------------------------------------------------------------------------------------------------------------------------------------------------------	------------------------------------------------------------------------------------------------------------------------------------------------------------------------------------------

FOR CANADIAN INSTALLATIONS
POUR INSTALLATIONS CANADIENNES

CAUTION: NOT SUITABLE FOR USE ON SYSTEMS EXCEEDING 150V-TO-GROUND.
ATTENTION: NE CONVIENT PAS AUX INSTALLATIONS DE PLUS DE 150 V A LA TERRE.

PRINTED FROM D155591 P01

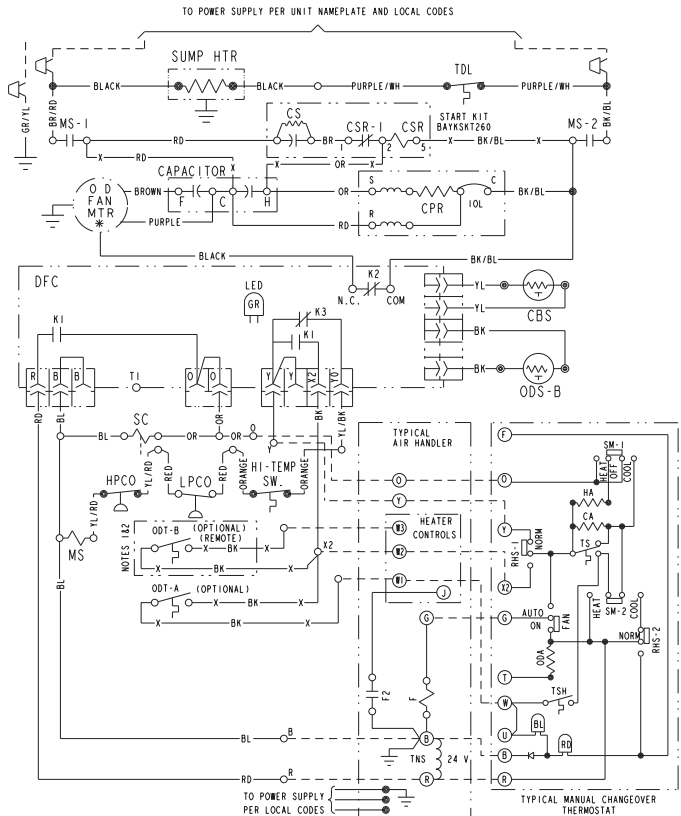

NOTES:

1. IF ODT-B IS NOT USED, ADD JUMPER BETWEEN W2 & W3 AT AIR HANDLER.
IF USED, ODT-B MUST BE MOUNTED REMOTE OF CONTROL BOX IN AN APPROVED WEATHER PROOF ENCLOSURE.
2. IF ODT-A IS NOT USED, ADD JUMPER BETWEEN W1 & W2 AT AIR HANDLER.
3. LOW VOLTAGE (24 V.) FIELD WIRING MUST BE 18 AWG MIN.

<p>⚠ WARNING HAZARDOUS VOLTAGE! DISCONNECT ALL ELECTRIC POWER INCLUDING REMOTE DISCONNECTS BEFORE SERVICING. FAILURE TO DISCONNECT POWER BEFORE SERVICING CAN CAUSE SEVERE PERSONAL INJURY OR DEATH!</p>	<p>⚠ CAUTION USE COPPER CONDUCTORS ONLY! UNIT TERMINALS ARE NOT DESIGNED TO ACCEPT OTHER TYPES OF CONDUCTORS. FAILURE TO DO SO MAY CAUSE DAMAGE TO THE EQUIPMENT!</p>
-----------------------------------------------------------------------------------------------------------------------------------------------------------------------------------------------------------------------------	------------------------------------------------------------------------------------------------------------------------------------------------------------------------------------------

FOR CANADIAN INSTALLATIONS
POUR INSTALLATIONS CANADIENNES

CAUTION: NOT SUITABLE FOR USE ON SYSTEMS EXCEEDING 150V-TO-GROUND.
ATTENTION: NE CONVIENT PAS AUX INSTALLATIONS DE PLUS DE 150 V A LA TERRE.

PRINTED FROM D155592 P01

Electrical Data

SCHEMATIC DIAGRAMS

4TWR3060A

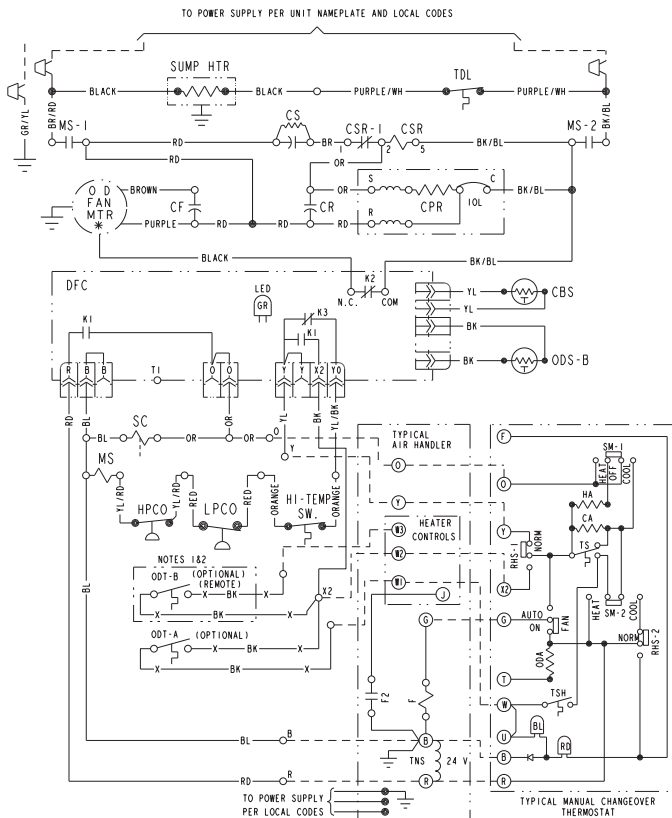

NOTES:

1. IF ODT-B IS NOT USED, ADD JUMPER BETWEEN W2 & W3 AT AIR HANDLER. IF USED, ODT-B MUST BE MOUNTED REMOTE OF CONTROL BOX IN AN APPROVED WEATHER PROOF ENCLOSURE.
2. IF ODT-A IS NOT USED, ADD JUMPER BETWEEN W1 & W2 AT AIR HANDLER.
3. LOW VOLTAGE (24 V.) FIELD WIRING MUST BE 18 AWG MIN.

<p>⚠ WARNING HAZARDOUS VOLTAGE! DISCONNECT ALL ELECTRIC POWER INCLUDING REMOTE DISCONNECTS BEFORE SERVICING. FAILURE TO DISCONNECT POWER BEFORE SERVICING CAN CAUSE SEVERE PERSONAL INJURY OR DEATH!</p>	<p>⚠ CAUTION USE COPPER CONDUCTORS ONLY! UNIT TERMINALS ARE NOT DESIGNED TO ACCEPT OTHER TYPES OF CONDUCTORS. FAILURE TO DO SO MAY CAUSE DAMAGE TO THE EQUIPMENT!</p>
-----------------------------------------------------------------------------------------------------------------------------------------------------------------------------------------------------------------------------	------------------------------------------------------------------------------------------------------------------------------------------------------------------------------------------

FOR CANADIAN INSTALLATIONS
POUR INSTALLATIONS CANADIENNES

CAUTION: NOT SUITABLE FOR USE ON SYSTEMS EXCEEDING 150V-TO-GROUND.
ATTENTION: NE CONVIENT PAS AUX INSTALLATIONS DE PLUS DE 150 V A LA TERRE.

PRINTED FROM D155593 P01

LEGEND

COLOR OF WIRE		
BK/BL	BLACK WIRE WITH BLUE MARKER	
COLOR OF MARKER		
BK	BLACK	OR ORANGE
BL	BLUE	RD RED
BR	BROWN	WH WHITE
		YL YELLOW
		GR GREEN
		PR PURPLE

SYMBOLS

	24 V. LINE V.	} FACTORY WIRING
	24 V. LINE V.	
		} FIELD WIRING
		} FIELD INSTALLED FACTORY WIRING
		GROUND
		JUNCTION
		WIRE NUT OR CONNECTOR
		COIL
		CAPACITOR
		RELAY CONTACT (N.O.)
		RELAY CONTACT (N.C.)
		THERMISTOR
		INTERNAL OVERLOAD PROTECTOR
		PRESSURE ACTUATED SWITCH
		TEMP. ACTUATED SWITCH
		POL. PLUG FEMALE HOUSING (MALE TERM.)
		POL. PLUG MALE HOUSING (FEMALE TERM.)
		RESISTOR OR HEATING ELEMENT
		MOTOR WINDING
		TERMINAL

CA	COOLING ANTICIPATOR	LPCO	LOW PRESSURE CUTOFF SW.
CBS	COIL BOTTOM SENSOR	MS	COMPRESSOR MOTOR CONTACTOR
CF	FAN CAPACITOR	ODA	OUTDOOR ANTICIPATOR
CN	WIRE CONNECTOR	OFT	OUTDOOR FAN THERMOSTAT
CPR	COMPRESSOR	ODS	OUTDOOR TEMPERATURE SENSOR
CR	RUN CAPACITOR	ODT	OUTDOOR THERMOSTAT
CS	STARTING CAPACITOR	RHS	RESISTANCE HEAT SWITCH
CSR	CAPACITOR SWITCHING RELAY	SC	SWITCHOVER VALVE SOLENOID
DFC	DEFROST CONTROL	SM	SYSTEM "ON-OFF" SWITCH
F	INDOOR FAN RELAY	TDL	DISCHARGE LINE THERMOSTAT
HA	HEATING ANTICIPATOR	TNS	TRANSFORMER
HPCO	HIGH PRESSURE CUTOFF SW.	TS	HEATING-COOLING THERMOSTAT
IOL	INTERNAL OVERLOAD PROTECTOR	TSH	HEATING THERMOSTAT



Dimensions

4TWR3 OUTLINE DRAWING

NOTE: ALL DIMENSIONS ARE IN MM (INCHES)

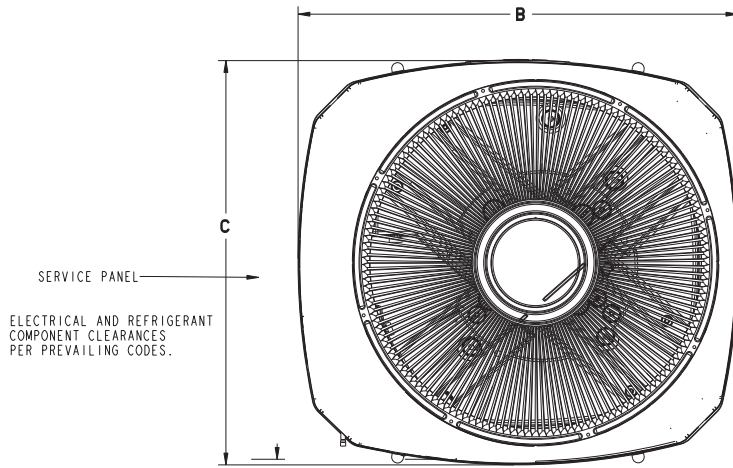

TOP DISCHARGE AREA SHOULD BE UNRESTRICTED FOR AT LEAST 1524 (5 FEET) ABOVE UNIT. UNIT SHOULD BE PLACED SO ROOF RUN-OFF WATER DOES NOT POUR DIRECTLY ON UNIT, AND SHOULD BE AT LEAST 305 (12") FROM WALL AND ALL SURROUNDING SHRUBBERY ON TWO SIDES. OTHER TWO SIDES UNRESTRICTED.

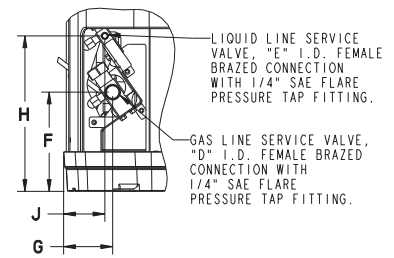
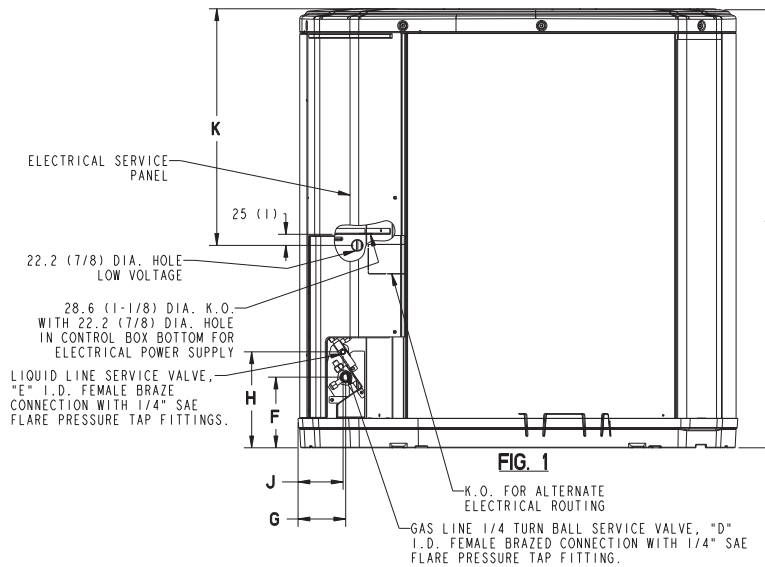

FIG. 2

MODELS	BASE	FIG.	A	B	C	D	E	F	G	H	J	K
4TWR3018A	3	2	730 (28-3/4)	829 (32-5/8)	756 (29-3/4)	1/2	1/4	127 (5)	76 (3)	197 (7-3/4)	57 (2-1/4)	508 (20)
4TWR3024A	3	2	730 (28-3/4)	829 (32-5/8)	756 (29-3/4)	5/8	5/16	127 (5)	76 (3)	197 (7-3/4)	57 (2-1/4)	508 (20)
4TWR3030A	3	2	933 (36-3/4)	829 (32-5/8)	756 (29-3/4)	3/4	5/16	143 (5-5/8)	92 (3-5/8)	210 (8-1/4)	79 (3-1/8)	508 (20)
4TWR3036A	4	1	943 (37-1/8)	946 (37-1/4)	870 (34-1/4)	3/4	3/8	152 (6)	98 (3-7/8)	219 (8-5/8)	86 (3-3/8)	508 (20)
4TWR3042A	4	1	943 (37-1/8)	946 (37-1/4)	870 (34-1/4)	3/4	3/8	152 (6)	98 (3-7/8)	219 (8-5/8)	86 (3-3/8)	508 (20)
4TWR3048A	4	1	1045 (41-1/8)	946 (37-1/4)	870 (34-1/4)	7/8	3/8	152 (6)	98 (3-7/8)	219 (8-5/8)	86 (3-3/8)	508 (20)
4TWR3060A	4	1	1045 (41-1/8)	946 (37-1/4)	870 (34-1/4)	7/8	3/8	152 (6)	98 (3-7/8)	219 (8-5/8)	86 (3-3/8)	508 (20)

From Dwg. 21D152898 Rev. 14



Mechanical Specification Options

General

The 4TWR3 is fully charged from the factory for up to 15 feet of piping. This unit is designed to operate at outdoor ambient temperatures as high as 115°F. Cooling capacities are matched with a wide selection of air handlers and furnace coils that are ARI certified. The unit is UL listed. Exterior is designed for outdoor application.

Casing

Unit casing is constructed of heavy gauge, G90 galvanized steel and painted with a weather-resistant powder paint on all louvers, panels, prepaint on all other panels. Corrosion and weatherproof CMBP-G30 DuraTuff™ base.

Refrigerant Controls

Refrigeration system controls include condenser fan, compressor contactor and high pressure switch. High and low pressure controls are inherent to the compressor. A factory installed liquid line drier is standard.

Compressor

The Climatuff® compressor features a 10 year limited warranty, internal over temperature and pressure protection and total dipped hermetic motor. Other features include: roto lock suction and discharge refrigerant connections, centrifugal oil pump and low vibration and noise.

Condenser Coil

The outdoor coil provides low airflow resistance and efficient heat transfer. The coil is protected on all four sides by louvered panels and has a 10 year limited warranty.

Low Ambient Cooling

As manufactured, this unit has a cooling capability to 55°F. The addition of an evaporator defrost control permits operation to 40°F. The addition of an evaporator defrost control with TXV permits low ambient cooling to 30°F.

Accessories

Thermostats — Cooling only and heat/cooling (manual and automatic changeover). Sub-base to match thermostat and locking thermostat cover.

Evaporator Defrost Control — See Low Ambient Cooling.



ARI Standard
210/240 UHP



TRANE®

Trane
www.trane.com

06/08

Trane has a policy of continuous product and product data improvement and it reserves the right to change design and specifications without notice.