



32- 5053- 03

Available in French Canadian (FC)

User's Information Guide

Condensing Gas Furnaces- Fan Assisted Combustion System with Whole House Air Cleaner

IMPORTANT: Users **MUST** read all instructions in the manual. All manuals **MUST** be kept for future reference.

SAFETY SECTION

Safety signal words are used to designate a degree or level of seriousness associated with a particular hazard. The signal words for safety markings are **WARNING**, and **CAUTION**.

- a. **WARNING** indicates a potentially hazardous situation which, if not avoided, could result in death or serious injury.
- b. **CAUTION** indicates a potentially hazardous situation which, if not avoided, may result in minor or moderate injury. It is also used to alert against unsafe practices and hazards involving only property damage.

Contents

Safety Section	1
General Information	3
To Start the Furnace	4
Proper Maintenance	6
The Problem Solver	7
Regular Dealer Maintenance	8
Warranty	10

WARNING

If the information in this manual is not followed exactly, a fire or explosion may result causing property damage, personal injury or loss of life.

- Do not store or use gasoline or other flammable vapors and liquids or combustible materials in the vicinity of this or any other appliance.
- **WHAT TO DO IF YOU SMELL GAS**
 - Do not try to light any appliance.
 - Do not touch any electrical switch; do not use any phone in your building.
 - Immediately call your gas supplier from a neighbor's phone. Follow the gas supplier's instructions.
 - If you cannot reach your gas supplier, call the fire department.
- **DO NOT RELY ON SMELL ALONE TO DETECT LEAKS. DUE TO VARIOUS FACTORS, YOU MAY NOT BE ABLE TO SMELL FUEL GASES.**
 - U.L. recognized fuel gas and CO detectors are recommended in all applications, and their installation should be in accordance with the manufacturer's recommendations and/or local laws, rules, regulations, or customs.
- Installation and service must be performed by a qualified installer, service agency or the gas supplier.

WARNING

SAFETY WARNING

DO NOT USE THIS UNIT IF ANY PART HAS BEEN UNDER WATER. A FLOOD DAMAGED UNIT IS EXTREMELY DANGEROUS. ATTEMPTS TO USE THE FURNACE CAN RESULT IN FIRE OR EXPLOSION. A QUALIFIED SERVICE AGENCY SHOULD BE CONTACTED TO INSPECT THE FURNACE AND TO REPLACE ALL GAS CONTROLS, CONTROL SYSTEM PARTS, ELECTRICAL PARTS THAT HAVE BEEN WET OR THE FURNACE IF DEEMED NECESSARY.

FAILURE TO FOLLOW THIS WARNING COULD RESULT IN PROPERTY DAMAGE, PERSONAL INJURY OR DEATH.

WARNING

SAFETY WARNING

IN THE EVENT THAT ELECTRICAL, FUEL OR MECHANICAL FAILURES OCCUR, THE OWNER SHOULD IMMEDIATELY TURN OFF THE GAS SUPPLY AT THE MANUAL GAS VALVE LOCATED IN THE BURNER COMPARTMENT AND ELECTRICAL POWER TO THE FURNACE AND CONTACT SERVICER.

FAILURE TO FOLLOW THIS WARNING COULD RESULT IN PROPERTY DAMAGE, PERSONAL INJURY OR DEATH.

WARNING

SAFETY WARNING

SHOULD OVERHEATING OCCUR, OR THE GAS SUPPLY FAIL TO SHUT OFF, SHUT OFF THE MANUAL GAS VALVE TO THE FURNACE BEFORE SHUTTING OFF THE ELECTRICAL SUPPLY.

FAILURE TO FOLLOW THIS WARNING COULD RESULT IN PROPERTY DAMAGE, PERSONAL INJURY OR DEATH.

User's Information

The following warning complies with State of California law, Proposition 65.

WARNING

THIS PRODUCT CONTAINS FIBERGLASS WOOL INSULATION!

Fiberglass dust and ceramic fibers are believed by the State of California to cause cancer through inhalation. Glasswool fibers may also cause respiratory, skin, or eye irritation.

PRECAUTIONARY MEASURES

- Avoid breathing fiberglass dust.
- Use a NIOSH approved dust/mist respirator.
- Avoid contact with the skin or eyes. Wear long-sleeved, loose-fitting clothing, gloves, and eye protection.
- Wash clothes separately from other clothing: rinse washer thoroughly.
- Operations such as sawing, blowing, tear-out, and spraying may generate fiber concentrations requiring additional respiratory protection. Use the appropriate NIOSH approved respirator in these situations.

FIRST AID MEASURES

- Eye Contact** – Flush eyes with water to remove dust. If symptoms persist, seek medical attention.
- Skin Contact** – Wash affected areas gently with soap and warm water after handling.

WARNING

CARBON MONOXIDE POISONING HAZARD
FAILURE TO FOLLOW THE INSTALLATION AND OPERATION INSTRUCTIONS FOR THE VENTING SYSTEM'S OPERATION COULD RESULT IN CARBON MONOXIDE POISONING OR DEATH.

WARNING

SAFETY WARNING
BODILY INJURY CAN RESULT FROM HIGH VOLTAGE ELECTRICAL COMPONENTS, FAST MOVING FANS, AND COMBUSTIBLE GAS. DURING INSTALLATION AND SERVICING, THE ELECTRICAL SUPPLY MUST BE DISCONNECTED AND THE MAIN GAS VALVE MUST BE TURNED OFF.
FAILURE TO FOLLOW THIS WARNING COULD RESULT IN PROPERTY DAMAGE, PERSONAL INJURY OR DEATH.

WARNING

SAFETY WARNING
TO PREVENT INJURY OR DEATH DUE TO CONTACT WITH MOVING PARTS, TURN THE POWER TO THE FURNACE OFF BEFORE CLEANING OR SERVICING THE WHOLE HOUSE AIR CLEANER.
FAILURE TO FOLLOW THIS WARNING COULD RESULT IN PROPERTY DAMAGE, PERSONAL INJURY OR DEATH.

WARNING

ELECTRIC SHOCK HAZARD
THESE SERVICING INSTRUCTIONS ARE FOR USE BY QUALIFIED PERSONNEL ONLY. TO REDUCE THE RISK OF ELECTRIC SHOCK, DO NOT PERFORM ANY SERVICING OTHER THAN THAT CONTAINED IN THESE OPERATING INSTRUCTIONS UNLESS YOU ARE QUALIFIED TO DO SO.
FAILURE TO FOLLOW THIS WARNING COULD RESULT IN PROPERTY DAMAGE, PERSONAL INJURY OR DEATH.

WARNING

SAFETY WARNING
DO NOT ATTEMPT TO MANUALLY LIGHT THE FURNACE. FAILURE TO FOLLOW THIS WARNING MAY RESULT IN PERSONAL INJURY, PROPERTY DAMAGE, OR DEATH.

CAUTION

High Voltage is present within the air cleaner for operation. Turn the power off and wait at least 15 seconds to allow voltage to discharge

CAUTION

If the furnace is shut down during the cold weather months, provisions must be taken to prevent freeze-up of all water pipes and water receptacles..

CAUTION

Never operate your unit for either heating or cooling with filters removed.

CAUTION

Do NOT touch igniter. It is extremely hot.

CAUTION

The combustion air for your furnace must be fresh uncontaminated air. Paints, varnishes, laundry bleaches, detergents, many household cleaners, water softening salts, adhesives, and all such products release fumes containing compounds which could lead to early heat exchanger and vent system deterioration. Do NOT store these types of products near your furnace.

General Information

WARNING

SAFETY WARNING

BODILY INJURY CAN RESULT FROM HIGH VOLTAGE ELECTRICAL COMPONENTS, FAST MOVING FANS, AND COMBUSTIBLE GAS. DURING INSTALLATION AND SERVICING, THE ELECTRICAL SUPPLY MUST BE DISCONNECTED AND THE MAIN GAS VALVE MUST BE TURNED OFF.

FAILURE TO FOLLOW THIS WARNING COULD RESULT IN PROPERTY DAMAGE, PERSONAL INJURY OR DEATH.

WARNING

SAFETY WARNING

IMPROPER INSTALLATION, ADJUSTMENT, ALTERATION, SERVICE OR MAINTENANCE CAN CAUSE INJURY OR PROPERTY DAMAGE. FOR ASSISTANCE OR ADDITIONAL INFORMATION CONSULT A QUALIFIED INSTALLER, SERVICE AGENCY OR THE GAS SUPPLIER.

FAILURE TO FOLLOW THIS WARNING COULD RESULT IN PROPERTY DAMAGE, PERSONAL INJURY OR DEATH.

CAUTION

The combustion air for your furnace must be fresh uncontaminated air. Paints, varnishes, laundry bleaches, detergents, many household cleaners, water softening salts, adhesives, and all such products release fumes containing compounds which could lead to early heat exchanger and vent system deterioration. Do NOT store these types of products near your furnace.

IMPORTANT FACTS

This unit is equipped with an integrated high efficiency whole house electronic air cleaner. Careful consideration must be taken in the installation process to avoid personal injury or equipment damage. These instructions do not cover all variations in systems or provide for every possible contingency. Should further information be desired or particular problems arise which are not covered sufficiently by this manual, contact your local distributor or the manufacturer as listed on the furnace nameplate.

The flow of combustion and ventilating air must not be obstructed from reaching the furnace. Air openings provided in the casing of the furnace must be kept free of obstructions which would restrict airflow, thereby affecting efficiency and safe operation of your furnace.

Also, air openings provided to the area in which the furnace is installed and the space around the furnace shall not be blocked or obstructed. Keep this in mind should you choose to remodel the area which contains your furnace. If additional insulation is added after the furnace is installed, the area around the furnace must be inspected to ensure it is free and clear of insulation. If this furnace is installed in an attic or other insulated space it must be kept free and clear of all insulating materials as some insulating materials are combustible.

Furnaces must have air for proper performance. There must be a free flow of fresh air sufficient for efficient combustion and safe ventilation of your furnace.

Never store gasoline, combustible materials, or other flammable liquids or vapors near your furnace.

Carbon monoxide, fire or smoke can cause serious bodily injury, death, and/or property damage.

A variety of potential sources of carbon monoxide can be found in a building or dwelling such as gas-fired clothes dryers, gas cooking stoves, water heaters, furnaces and fireplaces. The U.S. Consumer Product Safety Commission recommends that users of gas-burning appliances install carbon monoxide detectors as well as fire and smoke detectors, listed by a nationally recognized agency (e.g. Underwriters Laboratories or International Approval Services), to help alert dwelling occupants of the presence of fire, smoke or unsafe levels of carbon monoxide.

NOTE: The manufacturer of your furnace does not test any detectors and makes no representations regarding any brand or type of detector.

Installing and servicing heating equipment can be hazardous due to gas and electrical components. Only trained and qualified personnel should install, repair or service heating equipment.

Untrained personnel can perform basic maintenance functions such as cleaning the whole house air cleaner COLLECTION CELL. All other operations must be performed by trained service personnel.

Parts and controls of this furnace are unique. Should service or modification be required, be sure your servicer uses only factory authorized parts, kits, or accessories for this furnace.

If you experience a problem with the operation of your furnace, check the "Problem Solver" section of this manual before you call for a possibly unneeded service call.

To Start the Furnace

Lighting instructions.

Your furnace does not use a continuously burning pilot flame. Therefore, manually lighting your furnace is not required. Your furnace is equipped with an automatic ignition system. It uses a hot surface ignition device that automatically lights the burners each time the thermostat signals the furnace to start.

⚠ WARNING

SAFETY HAZARD

DO NOT ATTEMPT TO MANUALLY LIGHT THE FURNACE. FAILURE TO FOLLOW THIS WARNING MAY RESULT IN PERSONAL INJURY, PROPERTY DAMAGE, OR DEATH.

⚠ CAUTION

If the furnace is shut down during the cold weather months, provisions must be taken to prevent freeze-up of all water pipes and water receptacles.

1. Please read all safety information in this book before operating furnace.
2. Set thermostat to lowest setting. Turn off all electric power to furnace.
3. Remove the furnace front panel to gain access to the main gas valve.
4. Turn gas cock knob clockwise or the toggle switch located on the main gas valve inside the unit to "OFF" position (see illustration on this page). If external gas cock is used, turn to "OFF" position (see illustration on next page). Allow 5 minutes for any gas within the unit to escape. LP gas being heavier than air may require forced ventilation.

8. When thermostat is satisfied, main burners will extinguish.
9. Restore electrical supply panel. If main burners fail to ignite, lower Comfort Control setting or disconnect electrical supply, wait 5 minutes, raise Comfort Control setting above indicated temperature.
10. If furnace will not light, turn "OFF" all gas and electricity to unit and call servicer or gas supplier.

For complete shutdown.

Turn gas cock knob on main gas valve to "OFF" position. Disconnect electrical supply to unit.

Whenever your house is to be vacant, arrange to have someone inspect your house for proper temperature. If your furnace should fail to operate, damage could result, such as frozen water pipes.

Flame Roll-out Device.

All models are equipped with a manual resetting roll-out switch located near the burners. In case of flame roll-out, the switch trips automatically shutting off all flow of gas. The switch must be manually reset by pressing the red reset button on the top of the switch.

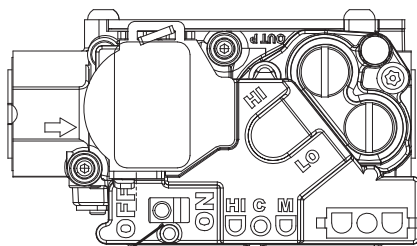

Gas Valve On/Off Toggle Switch

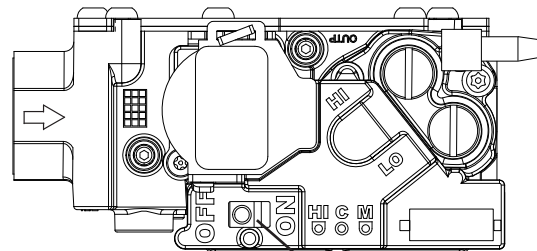

Gas Valve On/Off Toggle Switch

Your furnace may have a "Knob Switch" or a "Toggle Switch" to turn the gas ON or OFF.

If you smell gas STOP! Follow the "What To Do If You Smell Gas" instructions on the front cover of this book. If you don't smell gas, go to next step.

5. Turn gas cock knob counterclockwise or the toggle switch to "ON" marker (see illustration on this page). Turn the external gas cock back to the on position if you expect the furnace to light.
6. Replace the furnace front access panel.
7. Turn on main electrical supply and set thermostat to desired setting. Combustion blower will start and ignition device will start to heat up. After approximately 15 seconds main gas valve will open and burners will ignite.

User's Information

NOTE THE LOCATION OF THE MANUAL MAIN GAS SHUTOFF VALVE FOR YOUR FURNACE.

Have your installer or servicer show you the location if you have any questions.

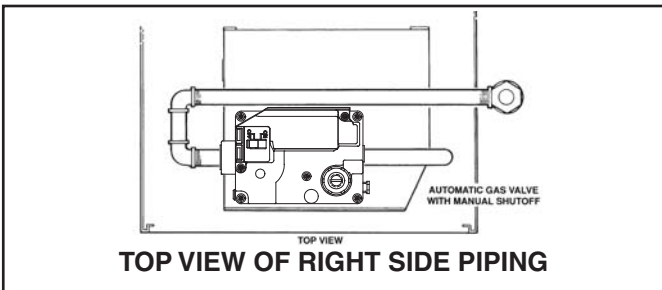
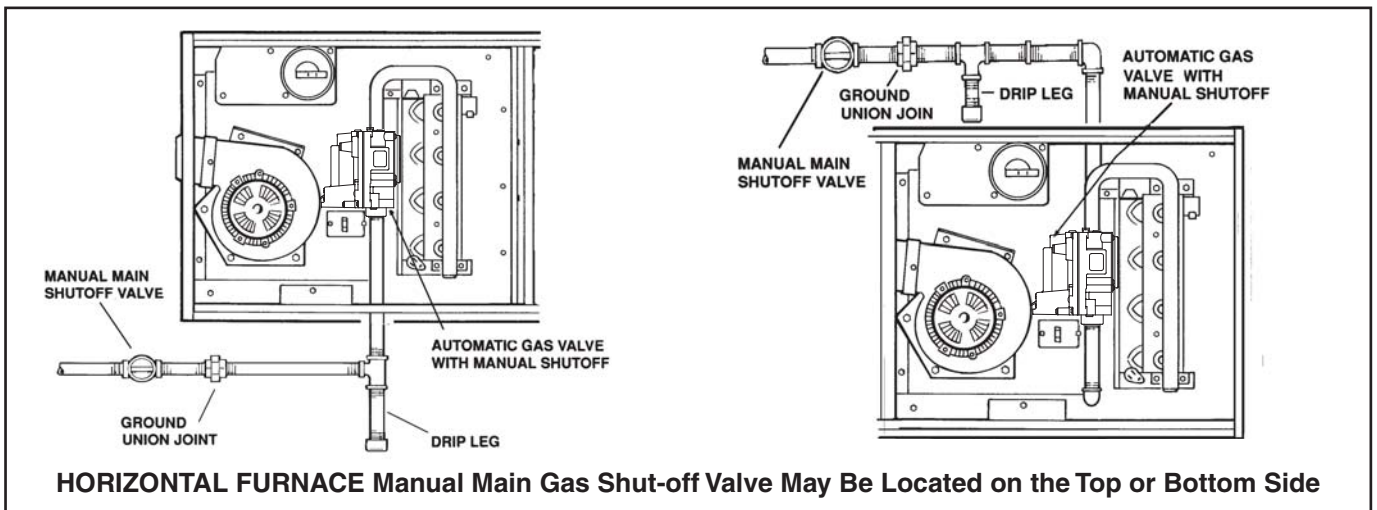
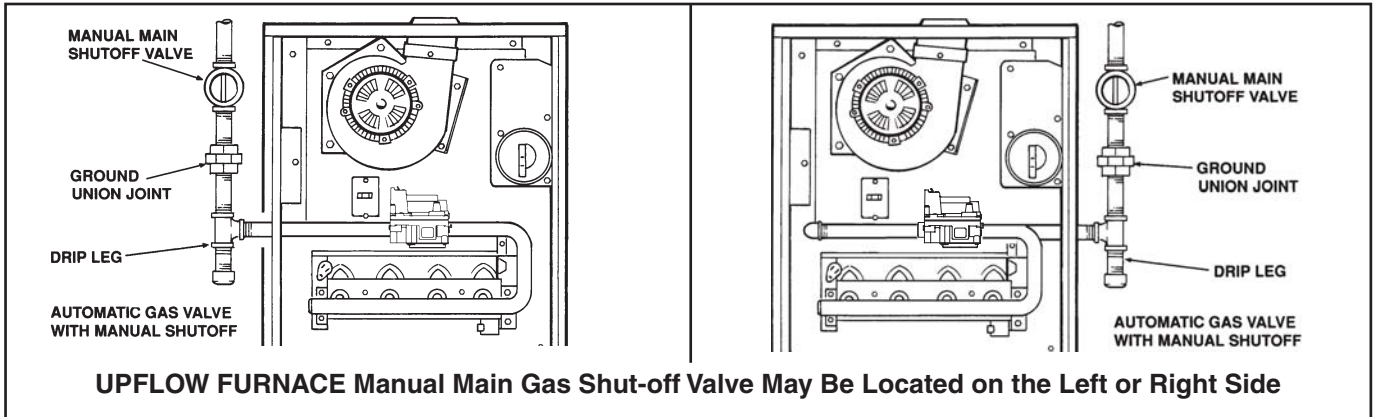

Proper Maintenance

WHOLE HOUSE AIR CLEANER

CAUTION

Never operate your unit for either heating or cooling with filters removed.

NOTE: *Whole House Electronic Air Cleaners are included with all of the Integrated Furnaces.*

A clean filter saves money.

When the furnace circulates and filters the air in your home, dust and dirt particles build up on the filter. Excessive accumulation can block the airflow, forcing the unit to work harder to maintain desired temperatures.

And the harder your unit has to work, the more energy it uses. So you pay more any time your system is running with a dirty filter.

WHOLE HOUSE AIR CLEANER MAINTENANCE

1. For maximum efficiency the COLLECTION CELL should be inspected and cleaned on a regular basis.

IMPORTANT: **A 30 to 90 day cleaning interval is normal for the COLLECTION CELL and should be adjusted based upon unit run time and the home environment.**

2. The FIELD CHARGER must be removed and cleaned only by a qualified service professional.
3. The FIELD CHARGER must be cleaned at least once a year.
4. The FIELD CHARGER may require more frequent cleaning in homes with high indoor relative humidity (greater than 65% RH).
5. Consult your service professional about cleaning intervals.

WARNING

SAFETY HAZARD

TO PREVENT INJURY OR DEATH DUE TO CONTACT WITH MOVING PARTS, TURN THE POWER TO THE FURNACE OFF BEFORE CLEANING THE WHOLE HOUSE AIR CLEANER COLLECTION CELL. FAILURE TO FOLLOW THIS WARNING COULD RESULT IN PROPERTY DAMAGE, PERSONAL INJURY OR DEATH.

WARNING

ELECTRICAL SHOCK HAZARD

RISK OF ELECTRIC SHOCK: THESE SERVICING INSTRUCTIONS ARE FOR USE BY QUALIFIED PERSONNEL ONLY. TO REDUCE THE RISK OF ELECTRIC SHOCK, DO NOT PERFORM ANY SERVICING OTHER THAN THAT CONTAINED IN THESE OPERATING INSTRUCTIONS UNLESS YOU ARE QUALIFIED TO DO SO. FAILURE TO FOLLOW THIS WARNING COULD RESULT IN PROPERTY DAMAGE, PERSONAL INJURY OR DEATH.

CAUTION

High Voltage is present within the air cleaner for operation. Turn the power off and wait at least 15 seconds to allow voltage to discharge.

NOTE: System Information

Before cleaning the coil or ducts in the furnace, remove the COLLECTION CELL and FIELD CHARGER from the air cleaner. Chemicals used during the cleaning of the Furnace, or ductwork can damage the air cleaner components and degrade the performance of the air cleaner.

CLEANING THE COLLECTION CELL

1. Turn the air conditioning system off at the Comfort Control and turn off service disconnect.
2. Remove Blower Door.
3. Slide COLLECTION CELL out of Furnace.

CLEANING

The COLLECTION CELL may be cleaned either by vacuuming (recommended method) or by washing.

VACUUM CLEANING

Remove the COLLECTION CELL from the conditioned space before vacuuming. Vacuum both sides of the COLLECTION CELL to clean.

WASHING

Use low-pressure water spray, such as a sink sprayer or garden hose to clean the COLLECTION CELL. Some residue may require warm water to be removed.

- Do NOT use soap or detergent in cleaning the COLLECTION CELL.
- Do NOT immerse the COLLECTION CELL completely in water.
- Do NOT place the COLLECTION CELL into a dishwasher to clean.
- ALLOW THE COLLECTION CELL TO DRY THOROUGHLY BEFORE REINSTALLING.

Slightly tap the COLLECTION CELL to remove water retained in the filter. Allow the COLLECTION CELL to dry thoroughly before reinstalling.

The Problem Solver

WARNING

CARBON MONOXIDE POISONING HAZARD
DO NOT ATTEMPT TO CHANGE THE VENTING SYSTEM.
FAILURE TO FOLLOW THE INSTALLATION AND OPERATION INSTRUCTIONS FOR THE VENTING SYSTEM'S OPERATION COULD RESULT IN CARBON MONOXIDE POISONING OR DEATH.

Keep your furnace looking like new for years.

Clean the enamel finish of your furnace with ordinary soap and water. For stubborn grease spots, use a household detergent. Lacquer thinner or other synthetic solvents may damage the finish.

A furnace is not a household appliance. It is complex and requires professional maintenance and repair.

That's why attempts at "do-it-yourself" repairs on an in-warranty unit may void the remainder of your warranty.

Other than performing the simple maintenance recommended in this manual, you should not attempt to make any adjustments to your furnace. Your dealer will be able to take care of any questions or problems you may have. A periodic inspection of your furnace should be made by a qualified service agency at the start of each heating season.

Save time and money. Before calling for service, check the following:

Problem	Possible Trouble	Possible Remedy
No Heating – Blower does not operate.	<ol style="list-style-type: none"> 1. Thermostat set incorrectly. 2. Blown fuse or tripped circuit breaker. 3. Failed component. 4. Burner does not ignite. 5. Main gas line turned off. 6. Blower door removed or ajar. 7. Lockout 	<ol style="list-style-type: none"> 1. Adjust thermostat. See operating instructions. 2. Replace or reset protective device or call for servicer. 3. Most controls are automatic and will recycle. If your unit still does not operate call for servicer. 4. Call servicer. 5. Have gas company check. 6. Close door securely to restore power to blower and gas valve. 7. Turn power on-off-on-off twice in 30 seconds.
Insufficient Heating – Blower operates continuously.	<ol style="list-style-type: none"> 1. Dirty air filtration system. 2. Blocked supply or return registers. 	<ol style="list-style-type: none"> 1. Clean Whole House Electronic Air Cleaner COLLECTION CELL. 2. Make sure registers are open and No obstacles blocking off the air.
No Heat – Vent motor is running.	Restricted or plugged furnace Condensate drain.	<ol style="list-style-type: none"> 1. Remove drain clamps to condensate trap and drain pan outlet. 2. Flush or clean drain blockage. 3. Reinstall clamps.
Unusual Noise		Call your servicer

Regular Dealer Maintenance

The following warning complies with State of California law, Proposition 65.

⚠ WARNING

HAZARDOUS GASES!
EXPOSURE TO FUEL SUBSTANCES OR BY-PRODUCTS OF INCOMPLETE FUEL COMBUSTION IS BELIEVED BY THE STATE OF CALIFORNIA TO CAUSE CANCER, BIRTH DEFECTS, OR OTHER REPRODUCTIVE HARM.

Regular maintenance to be performed by a qualified service professional ONLY.

⚠ WARNING

SAFETY WARNING

UNIT IS EQUIPPED WITH A BLOWER DOOR SWITCH WHICH CUTS POWER TO BLOWER AND GAS VALVE CAUSING SHUTDOWN WHEN DOOR IS REMOVED. UNIT MUST NOT BE ALTERED TO ALLOW OPERATION WITH THE BLOWER DOOR REMOVED. OPERATION WITH DOORS REMOVED OR AJAR CAN PERMIT THE ESCAPE OF DANGEROUS FUMES. ALL PANELS MUST BE SECURELY CLOSED AT ALL TIMES FOR SAFE OPERATION OF THE FURNACE.

⚠ WARNING

SAFETY WARNING

IN THE EVENT THAT ELECTRICAL, FUEL OR MECHANICAL FAILURES OCCUR, THE OWNER SHOULD IMMEDIATELY TURN OFF THE GAS SUPPLY AT THE MANUAL GAS VALVE LOCATED IN THE BURNER COMPARTMENT AND ELECTRICAL POWER TO THE FURNACE AND CONTACT SERVICER.

FAILURE TO FOLLOW THIS WARNING COULD RESULT IN PROPERTY DAMAGE, PERSONAL INJURY OR DEATH.

⚠ WARNING

SAFETY WARNING

SHOULD OVERHEATING OCCUR, OR THE GAS SUPPLY FAIL TO SHUT OFF, SHUT OFF THE MANUAL GAS VALVE TO THE FURNACE BEFORE SHUTTING OFF THE ELECTRICAL SUPPLY.

FAILURE TO FOLLOW THIS WARNING COULD RESULT IN PROPERTY DAMAGE, PERSONAL INJURY OR DEATH.

⚠ CAUTION

Do NOT touch igniter. It is extremely hot.

1. GENERAL INSPECTION – Examine the furnace installation for the following items:
 - a. All flue product carrying areas external to the furnace (i.e. chimney, vent connector) are clear and free of obstruction.
 - b. The vent connector is in place, slopes upward and is physically sound without holes or excessive corrosion.
 - c. The return air duct connection(s) is physically sound, is sealed to the furnace and terminates outside the space containing the furnace.

d. The physical support of the furnace should be sound without sagging, cracks, gaps, etc., around the base so as to provide a seal between the support and the base.

e. There are no obvious signs of deterioration of the furnace.

2. BLOWERS – The blower size and speed determine the air volume delivered by the furnace. The blower motor bearings are factory lubricated and under normal operating conditions usually do not require servicing. Annual cleaning of the blower wheel and housing is recommended for maximum air output, and this must be performed only by a qualified servicer or service agency.

3. IGNITER – This unit has a special hot surface direct ignition device that automatically lights the burners. Please note that it is very fragile and should be handled with care.

4. BURNER – Gas burners do not normally require scheduled servicing, however, accumulation of foreign material may cause a yellowing flame or delayed ignition. Either condition indicates that a service call is required. For best operation, burners must be cleaned annually using brushes and vacuum cleaner.

Turn off gas and electric power supply. To clean burners, remove top burner bracket and lift burner from orifice.

NOTE: Be careful NOT to break igniter when removing burners.

Clean burners with brush and/or vacuum cleaner. Reassemble parts by reversal of the above procedure.

NOTE: On LP (propane) units, some light yellow tipping of the outer mantle is normal. Inner mantle should be bright blue.

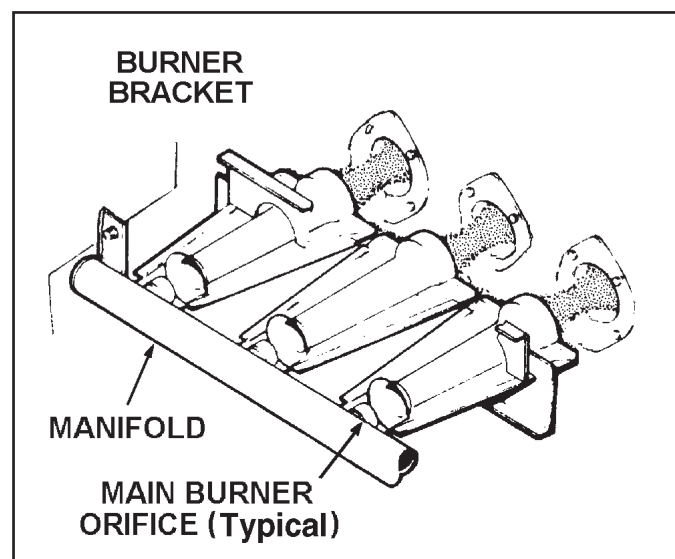

Natural gas units should not have any yellow tipped flames. This condition indicates that a service call is required. For best operation, burners must be cleaned annually using brushes and vacuum cleaner.

NOTE: On LP (propane) units, due to variations in BTU content and altitude, servicing may be required at shorter intervals.

5. **HEAT EXCHANGER/FLUE PIPE** – These items must be inspected for signs of corrosion, and/or deterioration at the beginning of each heating season by a qualified service technician and cleaned annually for best operation.
6. **CIRCUIT PROTECTION** – If blower or gas valve fail to operate, the cause could be the circuit breaker or a loose or blown fuse. Replace fuse or reset circuit breaker.
7. **OPERATION** – Your warm air furnace should not be operated in a corrosive atmosphere. Paint solvents, cleaning chemicals, spray propellants, and bleaches should not be used in the vicinity of the furnace during normal operation.
8. **CONDENSATE DRAINS** – If you have a cooling coil installed with your furnace, condensate drains should be checked and cleaned periodically to assure that condensate can drain freely from coil to drain. If condensate cannot drain freely water damage could occur. Furnace drain should also be checked & cleaned at the start of each heating season.
9. **AIR CIRCULATION** – To ensure increased comfort, the blower on this unit may be operated continuously for both heating and cooling. This will result in constantly filtered air and aid in maintaining more even temperatures by avoiding temperature stratification throughout the conditioned area. To accomplish constant air circulation, set your thermostat fan switch to “ON”. Continuous fan mode during cooling operation may not be appropriate in humid climates. If the indoor air exceeds 60% relative humidity or simply feels uncomfortably humid, it is recommended that the fan only be used in the AUTO mode.



File name	32-5053-03
Supersedes	32-5053-02
Date	12/08

Trane
6200 Troup Highway
Tyler, TX 75707

The manufacturer has a policy of continuous product and product data improvement, and it reserves the right to change design and specifications without notice.

Limited Warranty High Efficiency Condensing Gas Furnace with Whole House Air Cleaner UX2

(First letter may be preceded by an "A" or "T") (Parts Only)

Models Less Than 20 Tons for Residential Use*

This limited warranty is extended by the manufacturer to the original purchaser and to any succeeding owner of the real property to which the gas furnace is originally affixed and applies to products purchased and retained for use within the U.S.A. and Canada.

Beginning on January 1, 2010, R-22 refrigerant will no longer be used as a manufacturer-installed refrigerant as required by federal regulation. Following this date, depending on the availability of any remaining R-22 equipment, indoor model replacements may require that the entire system be R-410A compatible. Outdoor system components and possibly connecting line sets would need to be replaced in order to be compatible with indoor units containing R-410A refrigerant. Expenses associated with replacing system components that are not R-410A compatible will not be covered by the terms and conditions of the limited warranty.

The limited warranty period begins when installation is complete and the gas furnace start-up procedure has been properly completed, verified by installer's invoice or similar document. If installation completion and start-up date cannot be verified by installer's invoice or similar document, limited warranty coverage begins six (6) months after the date of manufacture based on the gas furnace serial number.

Limited Warranty

If any part of your gas furnace fails because of a manufacturing defect within five (5) years from the date the limited warranty period begins, Warrantor will furnish without charge the required replacement part F.O.B. nearest Parts Distribution point. Any local transportation, related service labor, and diagnosis calls, are not included.

Limited Lifetime Warranty

The primary and secondary heat exchanger, when installed to serve a single family residence or single condominium, is warranted to the original purchaser for use during his or her lifetime, provided the installation is in the original purchaser's primary, uninterrupted residence from the date the limited warranty period begins until discovery of a defect in the primary heat exchanger or secondary heat exchanger. The heat exchanger is warranted to a successor purchaser for a period of twenty (20) years from the date the limited warranty period begins for the gas furnace. Warrantor WILL AT ITS OPTION provide either a heat exchanger including secondary heat exchanger without charge F.O.B. nearest Parts Distribution point, or allow a credit in the amount of the then current wholesale price of an equivalent heat exchanger toward the purchase price of a comparable heating unit. Any local transportation, related service labor, and diagnosis calls, are not included.

This limited warranty does not apply if the gas furnace was purchased direct (i.e. from internet websites or auctions) on an uninstalled basis. Additionally, this limited warranty will not apply unless the gas furnace is: (1) installed by a licensed or qualified HVAC technician, (2) applied and installed in accordance with the manufacturer's recommendations in its Installer's Guide, and (3) in compliance with all industry standards, national, state, and local codes.

This limited warranty does not cover your gas furnace if it is damaged while in your possession; including, but not limited to (1) damage caused by unreasonable use of the gas furnace, (2) damage from failure to properly maintain the gas furnace as set forth in the Use and Care manual (refer to "Proper Maintenance" section), (3) damage that is not considered a manufacturing defect, such as acts of God, malfunctions or failures resulting from fire, water, storms, lightning, earthquake, theft, riot, misuse, abuse, increased utility usage costs, or (4) performance problems due to improper selection / equipment match-up, installation, or application.

THE LIMITED WARRANTY AND LIABILITY SET FORTH HEREIN ARE IN LIEU OF ALL OTHER WARRANTIES AND LIABILITIES, WHETHER IN CONTRACT OR IN NEGLIGENCE, EXPRESSED OR IMPLIED, IN LAW OF IN FACT, INCLUDING IMPLIED WARRANTIES OF MERCHANTABILITY AND FITNESS FOR PARTICULAR USE, AND IN NO EVENT SHALL WARRANTOR BE LIABLE FOR ANY INCIDENTAL OR CONSEQUENTIAL DAMAGES.

Some states do not allow limitations on how long an implied limited warranty lasts or do not allow the exclusion or limitation of incidental or consequential damages, so the above limitation or exclusion may not apply to you. This limited warranty gives you specific legal rights, and you may also have other rights which vary from state to state.

Parts will be provided by our factory organization through an authorized service organization in your area listed in the yellow pages. If you wish further help or information concerning this limited warranty, contact:

Residential Systems
6200 Troup Highway, Tyler, TX 75707
Attention: Consumer Relations

Or visit our website: www.trane.com/residential

TW-1015-3308

* This limited warranty is for residential usage of this equipment and not applicable when this equipment is used for a commercial application. A commercial use is any application where the end purchaser uses the product for other than personal, family or household purposes.



As an **ENERGY STAR** Partner, Trane has determined that this product meets the **ENERGY STAR** guidelines for energy efficiency.

